



1935

**Manual**

1982

کتاب

# بِسْمِ اللّٰهِ الرَّحْمٰنِ الرَّحِیْمِ

ترجمہ: شروع اللہ کے نام سے جو بڑا مہربان نہایت رحم والا ہے

Commander PTC got it Published from  
Faisal Press, Mangoch April 2012

# PTC VISION OF POLICING



## PTC MISSION/GOALS

Professional and dynamic leadership  
Partnership with community participation  
Professional development  
Recruitment, assessment and evaluation of staff and  
and livable environment  
Application and maintenance of resources  
Budgeting and fund management  
Innovation and progress  
Product, improvement through a scheme of incentives  
and penalties  
Formulation of rules, policies and procedures  
Accountability to Allah (J) public and stakeholders

**Commandant PTC got it Published From  
Fauji Press Hangu in April 2012.**



# **PTC VISION OF POLICING**



## **PTC MISSION / GOALS**

- To produce professional and dynamic leadership
- Combating crime with community partnership
- Continuous professional development
- Frequent monitoring, assessment and evaluation of staff and trainees
- Safe, clean and lively environment
  
- Efficient utilization and maintenance of resources.
- Effective time tabling and time management
- Realistic, creative and progressive curriculum
- A code of conduct, implemented through a scheme of incentives, rewards and penalties
  
- Strong emphasis on professionalism and character building
- Proper implementation of rules, policies and procedure
- Accountability to Allah (J.J) public and the department



## POLICE TRAINING COLLEGE HANGU



The history of Police Training College Hangu's Manual since 1935, is summarized below:-

1. PTS had been run by different Standing Orders issued from time to time.
2. Subsequently Sihala's Manual was used to run it.
3. In 1982, the then Principal drafted the first ever PTC Hangu Manual, got it approved by the Inspector General of Police, and introduced it.
4. In 2003, the then Commandant redrafted this Manual, got it approved by the Inspector General of Police, and enforced it.
5. From 2004 to 2011 sometimes Commandants preferred 2003 version and sometimes 1982 version.
6. In 2012, the Commandant, with the help of CLI and others, redrafted it, got it approved by the Addl: IGP Operations & Training and adopted it.

7

**TABLE OF CONTENTS-PTC HANGU, MANUAL 1982**

**CHAPTER - 1**

**ADMISSION POLICY**

<b>Rule No.</b>	<b>Title</b>	<b>Page No.</b>
1	Title and Extent	1
2	Object of Police Training College Hangu	1
3	Topographical Features and Location	1
4	Eligibility for Admission	1
5	Type of Examinations	3
6	Examination Board	4
7	Grades	5
8	Report	5

**CHAPTER No. 2**

**COURSES AND ALLIED MATTERS**

9	Formation of Companies	6
10	Courses	6



## CHAPTER No. 3

### ORGANIZATION

11	Organization of the College	13
12	Duties of the Commandant	14
13	Powers of the Commandant	15
14	Duties and Powers of the Deputy Commandant	16
14A	Duties of the DSP Administration	16
14B	Duties of the Chief Law Instructor	16
14C	Duties of the Controller of Examinations	17
15	Duties of Reserve Inspector	18
16	Duties of Chief Drill Instructor	19
17	Duties of the Lines Officer	20
18	Duties of the Lines Muharrir	21
19	Duties of Lines Muharrir	21
20	Duties of Kot Head Constable	21
21	Duties of Armourer	22
22	Duties of Tear Gas Instructor	22
23	Duty Officer	22
24	Duties of Assistant Duty Officer	22
25	Duties of Assistant Chief Drill Instructor	22

## CHAPTER 4.

### MISCELLANEOUS

<b>Rule No.</b>	<b>Title</b>	<b>Page No.</b>
26	Company Commanders	23
27	Company Colour	24
28	Formation of Class and Squad	24
29	Official of the Company	24
30	Registers and Records	25
31	Duties of Assistant Company Commanders	25
32	Duties of Company Head Constables (Havaldar)	26
33	Duties of Instructor	26
34	Duties of Company Monitor	27
35	Duties of Class Room Monitor	27
36	Games	27
37	Duties of the S.H.O Model Police Station	27
38	Duties of Station Clerk of Model Police Station	28
39	Duties of Officer In-charge Training Aids	28
40	Duties of Photographer	29
41	Duties of In-charge Library	29
42	Duties of In-charge PTC Equipment & Musketry Stores	29
43	Duties of In-charge Regimental Stores	30



44	In-charge Academic Block	30
45	Staff Room	30
46	Police Messes	30
47	Hospital	31
48	Band	31
49	Contractors	31
50	Repair to Buildings	32
51	Allotment of Family Quarters	32
52	Electricity, Gas & Water in Family Quarters	32
53	Provision of Electric Lights & Fans in Class Rooms	32
54	Cleanliness of Police Buildings & Quarters	32
55	Damage to Buildings	33
56	Misuse of Facility	33
57	Ranges	33
58	Method to Estimate Accommodation	33
59	College Gardens, Sports & Parade Grounds etc.	33
60	Kit Inspection	34
61	Repair and Alteration of Kits by College Tailors	34
62	Mufti Dress	34
63	Training Aid Equipment	35
64	Beds (Charpaes)	35
65	Multi Media & Computers	35
66	Arms & Ammunition	35
67	Demonstration Purposes	35
68	Practice Stock Ammunition	36
69	Districts to Provide Practice Ammunition	36
70	Musketry Equipment	36
71	Individual Responsibility of Arms	36
72	Gas Equipment-indent of	36
73	Storage of Gas Equipment	37
74	Distribution of Gas Equipment	37
75	Motor Transport	37
76	Duties of Drivers	37
77	Use of Vehicles	38
78	Recess	38
79	Duties of Staff during Recess	38
80	Leave to Staff	39
81	Leave to Trainees	39
82	Holidays	40
83	Quarantine	40
84	Medical Examination	41
85	Documents of Trainee	41
86	Transfer of Papers	41
87	Staff Promotion	41
88	Temporary Promotion in Local Vacancies	42



89	Accelerated Promotion	42
90	Quarterly Awards	42
91	Special Rewards	43
92	Discipline	43
93	Staff & Trainees Relations	43
94	Outside Recommendation	43
95	Channel of Communication	44
96	Desertion	44
97	Conduct of Hospital	44
98	Medical Attendance	44
99	Privately Owned Arms	45
100	Indisposition	45
101	Order Book	45
102	Roll Call	46
103	Standing Order	46
104	Authorized Social Work, KhpalKar	46
105	Keeping of Pet & Animals	46
106	Measures to be taken in case of an Epidemic	47
107	Sanitary and Cleanliness	47
108	Guard Duty	47
109	Emergency Duties	47
110	Method of Instruction	48
111	Use of Audio Visual & other Aids	48
112	Training in Drill	48
113	Guest Speaker	49
114	Visit to Places Outside the Institution	49
115	First Aid	49
116	Swimming	49
117	Musketry	49
118	Sanctioned Staff of PTC	49
119	Selection of Instructors	50
120	Sanctioned Strength of Law Staff	51
121	Qualifications for Posting to Police Training College	52
122	Pay of Trainees	52
123	Amenities for Staff & Trainees	53
124	End of Term Function	54
125	Visitor's Book	54
126	Prize Entitlement	54
127	Law Subjects	54
128	Drill Subjects	55
129	General	55
130	Recruits Training Centre	55
131	Misconduct	55
132	Standing Orders	56
133	Cheating in Examination	56

134	Security Deposits	56
135	Test Books	56
136	Shop Keepers	57
137	Instruction	57
138	Supervisory Officer	57
139	Duty Officer	57
140	Orderly Room	58

### **LIST OF FORMS OF THE MANUAL**

S. No.	Rule	Name of Form	For English=E For Urdu =U	Page No.
1	26(vii)	Application for Leave	U	59
2	30(b)	Company Record Register of In-service Trainee	U	60
3	30(b)(i)	Company Record Register of Pre-service Trainee	U	61
4	85(i)	Nominal Roll of Pre-service Trainee	U	62
5	85(ii)	Nominal Roll of In-service Trainee	U	63
6	121(iv)	Annual Report on the Working of Drill Instructors	U	64
7	121(iv)	Annual Report on the Working of Other Staff	U	65
8	138	Supervisory Report	U	66
9	139(g)	Daily Report of Inner Duty Officer	U	69
10	139(v)	Daily Report of Outer Duty Officer	U	71
11	140(a)	Request for Appearance in Orderly Room	U	73
12	140(b)	Recommendation Sheet for Reward	U	74



## CHAPTER - 1

### \*[ADMISSION POLICY]

#### \*[TITLE AND EXTENT]

##### Rule No. 1

- i. This Manual may be called the Police Training College, Hangu, Manual 1982. It will also extend to all other Recruit's Centers in \*[Khyber Pakhtunkhwa].
- ii. This shall come into force at once.

#### OBJECT OF \*[POLICE TRAINING COLLEGE HANGU]

##### Rule No. 2

\*[Deleted]

#### \*[TOPOGRAPHICAL] FEATURES AND LOCATION.

##### Rule No. 3

\*[Deleted]

#### ELIGIBILITY FOR ADMISSION

##### Rule No. 4

- i. This Institution is primarily to train the \*[Khyber Pakhtunkhwa] Police personnel in various professional fields. However, with the concurrence of the \*[Provincial Police Officer, Khyber Pakhtunkhwa] the Police officers of other provinces of Pakistan and other departments may also be admitted for Training subject to the payment of the training charges, fixed by the PPO.
- ii. All officers deputed for training shall bring with them their full uniform and other articles as may be necessary.
- iii. No trainee shall wear badges of his rank during the training.
- iv. No trainee will be admitted to the \*[College] after the prescribed date without the prior sanction of the Commandant, subject to the general or special orders of the \*[Provincial Police Officer, Khyber Pakhtunkhwa.]
- v. \*[All Trainees and recruits undergoing pre-services Training will not be considered qualified until they are declared pass in all the law, drill, weapon handling etc.subjects. In case of their failure in subjects in any number, they

---

\* Substituted vide CPO, Pesh: Memo: No. 789/PA/Oprs: dated 06.02.2012.

would be liable to re appear in the failed subjects in the exams of the subsequent term. For this purpose they would have two chances for reappearance.

No trainee/recruits shall be entitled to undergo any other course and in case of recruit to appear in A-1 exam until he/she qualifies the pre-service course.

All trainees of in-service courses will be required to re-appear in the final exams of the subsequent term of the respective courses.

- v(a). The Commandant has the authority to return a trainee back to district/unit, if he/she does not qualify for that course, he has been selected for.]
- vi. Presently the following courses are run at this \*[College].

<u>S.No.</u>	<u>Name of Course</u>	<u>Duration of Courses</u>	<u>Date of beginning</u>	<u>Date of ending</u>
1	Upper College Course	6 months	1 <sup>st</sup> April & 1 <sup>st</sup> October each year.	20 <sup>th</sup> September & 20 <sup>th</sup> March each year.
2	Probationers PSIs Course	-do-	-do-	-do-
3	Intermediate College Course	-do-	-do-	-do-
4	Lower College Course	-do-	-do-	-do-
5	Drill Instructor Course	9 months	*[On required basis]	*[After completion of course]
6	Weapon Training Course	3 months	1 <sup>st</sup> January, 1 <sup>st</sup> April, 1 <sup>st</sup> July & 1 <sup>st</sup> October each year.	20 <sup>th</sup> March, 20 <sup>th</sup> June, 20 <sup>th</sup> September & 20 <sup>th</sup> December each year.
7	Platoon Commander Course	-do-	-do-	-do-
8	Section Commander Course	-do-	-do-	-do-
9	Tear Gas Course	1 month	-do-	After 30 days
10	Lines Officer Course	1 month	16 <sup>th</sup> January & 16 <sup>th</sup> July each year.	15 <sup>th</sup> February & 15 <sup>th</sup> August each year.
11	Recruit's Course	9 months	1 <sup>st</sup> January, 1 <sup>st</sup> April, 1 <sup>st</sup> July	20 <sup>th</sup> September, 20 <sup>th</sup> December,

\* Substituted vide CPO,

Pesh: Memo:

No.789/PA/ Oprs:

Dt: 06.02.2012.



& 1<sup>st</sup> October      20<sup>th</sup> March &  
each year.            20<sup>th</sup> June each  
year.

- vii. Under the orders of the \*[Provincial Police Officer] further courses can be introduced to improve the efficiency of the officers according to the needs of the future day to day requirements for which the syllabus and the period are to be specified according to the requirements of the courses.
- viii. Trainees shall be trained in the subjects of law, drill and musketry or in any other subjects according to the syllabus prescribed and approved for each of the courses by the \*[Provincial Police Officer] from time to time.

## **TYPE OF EXAMINATIONS**

### **Rule No. 5**

There shall be two types of examinations:-

(a) **Quarterly Test.**

Quarterly test in law subjects will be held every after every three months and conducted by the \*[Controller of Examinations] under his direct supervision in order to:-

- i. Measure the extent to which trainees have gained knowledge of law.
- ii. Create enthusiasm and incentive in the trainees so that they may take keen interest in their studies.
- iii. Lay emphasis on the important aspects of the subjects for improvement.
- iv. Evaluate and measure the quality and suitability of instructional technique.

The result of this test will help the \*[Commandant] / Board in awarding grace marks to qualify the final examinations. The result of the tests shall be computerized class-wise by the \*[Controller of Examinations].

(b) **Final Examination**

These examinations shall be held \*[in the syllabus approved for courses by the Provincial Police Officer, Khyber Pakhtunkhwa,] on the conclusion of training for:-

- i. Declaring as to whether a trainee has successfully completed the course or not.
- ii. Awarding grades or merit position, which will affect the prospects of promotion in the future career.
- iii. Assessing whether desired learning objective of the course have adequately been achieved.

---

\* Substituted vide CPO, Pesh: Memo: No 789/PA/Oprs: dated 06.02.2012.



- iv. Making future prediction about the performance of the trainees and his suitability for any particular job.

In \*[College] sheet these remarks will be inserted by the \*[Commandant].

The \*[Commandant] may withhold the result of any trainee who has not taken care of his liabilities.

**(c) Conduct of Final Examination**

- i. \*[All final examinations shall be conducted through a board constituted by the Commandant.]  
\*[Deleted.]
- ii. The passing marks in each subject of law and drill and in aggregate for each of the following courses will be as under:-

Recruit course Literate / Illiterate	i. Pass marks = *[40%] in each subject ii. Aggregate = *[50%]
Lower, Intermediate, Upper & other courses/Probationer PSI's Courses.	i. Pass marks = *[40%] in each subject ii. Aggregate = *[50%]

**iii. Grace Marks**

\*[The Commandant shall have the power in respect of recruits and trainees of all courses to award up to 10% grace marks in any individual failed subject (but not in more than three subjects). No such concession shall be given in aggregate score.]

- iv. The \*[Commandant] may examine the system of examinations in other institutions and consider its applicability in Police Training \*[College] Hangu.

**EXAMINATION BOARD**

**Rule No. 6**

The examination board shall be consisted of the following officers.

- |   |           |
|---|-----------|
| i. Commandant   | President |
| ii. Two officers from training institutions.                                | Members   |
| iii. Two or at least one officer from outside the institution, if available | Member(s) |

\* Substituted vide CPO, Pesh: Memo: No. 789/PA/Oprs: dated 06.02.2012.

**GRADES.**

**Rule No. 7**

\*[Deleted]

**Rule No. 8**

**REPORT.**

\*[Deleted]

---

\* Substituted vide CPO, Pesh: Memo: No. 789/PA/Oprs: dated 06.02.2012.



## CHAPTER No. 2

### \*[COURSES AND ALLIED MATTERS.]

#### \*[FORMATION OF COMPANIES]

##### Rule No. 9

- i. All recruits received for training will be divided into three companies \*[…], each consisting of adequate number of Recruits. A competent officer from staff shall be assigned the job of company commander of each company. They will also be provided with extra staff designated as Assistant Company Commander and Company Hawaldars if needed. Assistant Company Commanders will be selected out of \*[Sub-inspectors or Assistant Sub-inspectors] whereas Company Havaldars out of \*[Head Constables or Constables] of the P.T.C staff who will be assisted by other staff officers junior to them in rank to assist the Company Commander.
- ii. The Upper, Probationer P.S.I.s, A.S.I.s and Intermediate Classes will form a Fourth Company. The Lower class will form fifth Company. The Drill Instructors Class, Weapons Class, Section Commander Class, Platoon Commander Class and Tear Gas Class will form sixth company. Names of the companies shall be allotted, from time to time, by the Commandant.
- iii. Training to all types of trainees on ground work will be arranged by the Chief Drill Instructor, whereas legal education arrangements for them will be made by the Chief Law Instructor.
- iv. If needed, more companies may be raised in case special courses are started under the orders of the Provincial Police Officer.

#### \*[COURSES]

##### Rule No. 10

###### i. \*[RECRUIT'S COURSE]

The recruits will finally be examined in subjects approved for recruit course.

The Controller of examinations, under the guidance of the \*[Commandant], or any other officer authorized by him shall set the examination papers. The answer papers shall be marked by a group of examiners nominated by the Controller of examinations.

Each examiner shall generally mark one question of each paper.

A recruit shall have to secure 40% marks in each subject and 50% marks in aggregate. Recruit who secures 70% marks or above shall be considered to have passed the recruit course in category 'A'. Those who secure 50% marks but less than

---

\* Substituted vide CPO, Pesh: Memo: No. 789/PA/Oprs: dated 06.02.2012.



70% will be considered to have passed the recruit course in category 'B'.

Every recruit shall fire 300 rounds of 7.62 bore. Out of which 218 rounds will be fired for practice and the remaining 82 rounds for final examination as per detail given below.

- i. For Assault Firing = 54 rounds
- ii. For Sniper Firing = 28 rounds]

### **ii. \* [LOWER COLLEGE COURSE**

Total intake of the Lower Course will be fixed by the PPO from time to time. The object of this training course is to inculcate in the trainees the sense of responsibility and to equip them with the knowledge of law and practical police work to justify promotion to the rank of Head Constable.

#### **Eligibility.**

He should be on promotion list B-I

- a. He should be not more than 33 of years age
- b. He should be mentally and physically fit.

Every trainee will fire 300 rounds of 7.62 bore. Out of which 218 rounds will be fired for practice and the remaining 82 rounds for final examination as per detail given below.

- i. For Assault Firing = 54 rounds
- ii. For Sniper Firing = 28 rounds]

### **iii. \* [INTERMEDIATE COLLEGE COURSE.**

Total intake of the intermediate college course will be fixed for each term, from time to time, by the Provincial Police officer.

#### **Eligibility for admission:**

- a. He shall be confirmed Head Constable on promotion list C-I.
- b. He shall not be more than 43 years age.
- c. He should be mentally and physically fit.

Every trainee will fire 300 rounds of 7.62 bore. Out of which 250 rounds will be fired for practice and the remaining 50 rounds for final examination as per detail given below.

- i. For Assault Firing = 30 rounds
- ii. For Sniper Firing = 20 rounds

\* Substituted vide CPO, Pesh: Memo: No. 789/PA/Oprs: dated 06.02.2012.

The trainees of this class will complete six months training in the approved course. Main emphasis will be laid on making them good investigating officers. It is essential to inculcate in the trainees the qualities of dedication, self-confidence and ability to command.]

#### **iv. UPPER COLLEGE COURSE.**

\*[Total intake of the upper college course will be fixed, from time to time, by the Provincial Police officer.

##### **Eligibility for admission:**

- a. He shall be confirmed as Assistant Sub Inspector and on promotion list "E".
- b. He shall not be more than 48 years of age.
- c. He should be mentally and physically fit.

Every trainee of this course shall fire 300 rounds of 7.62 bore and 50 rounds of 9MM bore. Detail is as under:]

- i. \*[Rounds of 7.62 bore:
  - a. For Practice Firing = 280 rounds
  - b. For Final examination = 20 rounds
- ii. Rounds of 9 MM bore:
  - a. For Practice Firing = 40 rounds
  - b. For Final Examination = 10 rounds

The trainees of this course shall complete the specified period of training as mentioned in rule 4 (vi) in law and drill subjects. Main emphasis shall be laid on making them good preventive and investigating officers. It is essential to inculcate in the trainees the qualities of self-confidence commitment and ability to command.]

#### **v. \*SUB-INSPECTOR LEGAL COURSE.**

The total intake will be fixed by the Provincial Police Officer.

The trainees of this course shall be examined in the approved syllabus drafted by the board of examiners constituted by the Commandant.

Every trainee of this course shall fire 50 rounds of 9MM bore. The detail is as under:

- a. For Practice Firing = 40 rounds
- b. For Final Examination = 10 rounds]

---

\* Substituted vide CPO. Pesh Memo: No. 789/PA/Oprs: dated 06.02.2012.



## v. PROBATIONER ASIs TRAINING

Probationer Assistant Sub Inspectors of Police, directly recruited in Police Department shall have to undergo training for one year continuously at \*[P.T.C] Hangu. For the first six months they will join Lower \*[College] Course, and after successful completion of this course, they will be promoted to the Intermediate \*[College] course for next six months. In case they cannot qualify the course of any of the classes, they will be given \*[two chances]. If they fail again, the case will be referred to the Deputy Inspector General of Police, of the respective Range for discharge under Police Rule 12.8 of the Punjab Police Rule 1934 with intimation to the \*[Provincial Police Officer, Khyber Pakhtunkhwa].

### \*[PASI Lower Course

Every trainee of this course shall fire 300 rounds of 7.62 bore. Out of which 218 rounds will be fired for practice and the remaining 82 rounds for final examination as per detail given below.

- i. For Assault Firing = 54 rounds
- ii. For Sniper Firing = 28 rounds

### PASI Intermediate Course

Every trainee of this course shall fire 300 rounds of 7.62 bore. Out of which 218 rounds will be fired for practice and the remaining 82 rounds for final examination as per detail given below.

- i. For Assault Firing = 54 rounds
- ii. For Sniper Firing = 28 rounds]

## vii. MODE OF ALLOTMENT OF SEATS FOR DRILL COURSE.

\*[Total intake for this course will be fixed by the Provincial Police Officer keeping in view the strength of distt/ units.]

## viii. DRILL INSTRUCTOR COURSE.

\*[First paragraph deleted]

The \*[District Police Officers and in case of FRP/SPL, the Superintendents of Police of the respective regions], shall personally select smart, literate constables of good moral character and physique who possess an aptitude for Drill. They shall be required to pass the following physical efficiency tests as prescribed in Police Rule 19.20 (I). Due consideration shall be given to the note of the \*[Commandant], if any, on their College sheet regarding suitability for a Course:-



### Suitability Test.

- a. Race 100 Meters in 13<sup>2/5</sup> Second.
- b. Long jump = 15 feet.
- c. High jump = 04 feet.
- d. Age not more than 30 years.
- e. Recruit Course qualified.
- f. Three years' service excluding recruit training period.

If in any district suitable candidates with the above qualifications could not be found, the Range Deputy Inspector General of Police may be asked to authorize the transfer of suitable men from other districts.

The objective of this course is to meet the requirements of the Police Training Institutions and also the demand of the districts. The course provides an opportunity to the training \*[College] to pick and choose good and outstanding junior officers for employment as Instructors in the Training Institution from time to time. For this purpose a list shall be maintained by the \*[Commandant] of all the trainees, who have been through this course from time to time and have got good grades. In this way the demand of fresh Instructors from the district will be met in rotation.

All trainees in the course shall be required to obtain \*[40%] marks to qualify each subject. All subjects must be passed and the total aggregate will be \*[50%] to declare a trainee as qualified.

Note:- However, the \*[Commandant] may award grace marks in suitable cases, as mentioned in Rule 5 (c) (iv) in all ground courses.

Trainees will be examined by the \*[Board of Examiners constituted by the Commandant] and shall be graded as under:-

- i. Securing 75% marks or above shall be graded as first class.
- ii. Securing 70% marks or above but less than 75% shall be graded as second class.
- iii. Securing \*[50%] marks or above but less than 70% shall be graded as third class.

Those who obtain less than \*[50%] marks shall be declared failed. Qualifying Drill Instructors Course will be considered as if he has qualified Weapons Training Course, Platoon Commanders, Section Commanders Course and Tear Gas Course.

### ix. Weapon Training Course.

Those undergoing the Weapons Training Course shall be required to obtain \*[40%] marks in each subject. They shall be classified as 1<sup>st</sup> Class, 2<sup>nd</sup> Class

\* Substituted vide CPO. Pesh: Memo: No. 789/PA/Oprs: dated 06.02.2012



and 3<sup>rd</sup> Class. Following classes will be given according to marks obtained in the final test:-

- i. First class = 75% marks or above
- ii. 2<sup>nd</sup> class = 70% marks or above but less than 75%
- iii. 3<sup>rd</sup> class = \*[50%] marks or above but less than 70%

\*Eligibility:

- a. He shall not be more than 30 years of age.
- b. Not less than three years' service excluding recruit training course period.
- c. He must be qualified in recruit training course.
- d. He should be mentally and physically fit.]

Those who obtain less than \*[50%] marks in the aggregate will be considered

ii. Platoon Commanders Course.

The selection for Platoon Commanders Course will satisfy the following qualifications, which will be entered in the Nominal Rolls of the trainees sent to \*P.T.C):-

- a. Qualified in Section Commanders Course.
- b. Carrying List C-II.
- c. He must be Head Constable in the District.
- d. He should not be more than 45 years of age.
- e. \*[He should be mentally and physically fit.]

\*[Total intake to be decided by the P.P.O keeping in view the strength of Distt: Unit. Trainees shall be trained in the subjects approved for platoon commander course. Those who obtain 40% marks in each subject and 50%marks in the aggregate shall be declared to have qualified the course.]

iii. Section Commander Course.

\*Eligibility:

- a. He shall not be more than 40 years of age.
- b. His length of service must not be less than three years excluding recruit training course period.
- c. He should be mentally and physically fit.]

\*Men sent for Section Commander Course shall be qualified in the Weapon or Tear Gas Course. Their Nominal Rolls sent to PTC Hangu, shall show these qualifications.

\*Substituted vide CPO, Pesh: Memo: No. 789/PA/Oprs: dated 06.02.2012.

They shall undergo three months course. On their entrance to the College the Commandant, may return the sub-standard lot and those in case of whom the above conditions are not taken into consideration by the selecting authorities at the time of selection. All men in the course shall be required to obtain 40% marks to qualify in each subject. All subjects must be passed and total aggregate shall be 50% to declare a trainee as qualified.]

**xii. Tear Gas Course.**

Those attending the Tear Gas Course shall be required to obtain \*[40%] marks in each subject and \*[50%] in aggregate to qualify Tear Gas Course.

**\*[Eligibility:**

- a. He should not be more than 30 years of age.
- b. He should be qualified in recruit training course.
- c. His service must not be less than three years excluding recruit training course period.]

**xiii. Lines Officers Course.**

The total intake shall be 21 in number. Mostly Sub Inspector from various Ranges of the Province will be selected. They will be given training of leadership and trained for the duties pertaining to lines officer as laid down in Police Rule 17.3. They will also be given training in drill subjects.

---

\* Substituted vide CPO, Pesh: Memo: No. 789/PA/Oprs: dated 06.02.2012.



**CHAPTER No. 3**

**\*[ORGANIZATION]**

**\*[ORGANIZATION OF THE COLLEGE]**

**Rule No. 11.**

Subject to the General Instructions of the \*[Provincial Police Officer], the \*[Commandant] is responsible for the discipline, control and management of the \*[College]. \*[The organizational chart is as under.]

**\*[ORGANOGRAM]**

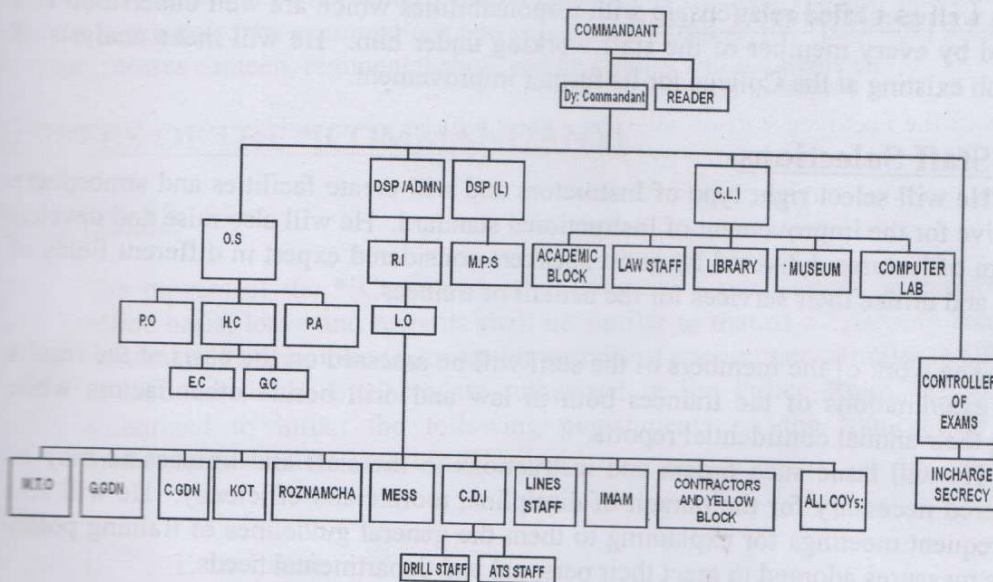

\* Substituted vide CPO, Pesh: Memo: No. 789/PA/Oprs: dated 06.02.2012.

## DUTIES OF THE COMMANDANT

### Rule No. 12.

The following will be the duties of the \*[Commandant], in addition to the overall supervision:

#### a. Planning

He will undertake planning on an extensive scale relating to the schedule of training. He will delegate routine work to the \*[Deputy Commandant] whenever required and direct his attention towards basic requirements of trainees, equipment, supplies, timing and chalking out course of action for the achievement of set objectives.

#### b. Organizing

He will make adequate arrangements about proper division of work and will create a well identified relationship with responsibilities which are well understood and accepted by every member of the staff working under him. He will make analysis of every job existing at the College for its further improvement.

#### c. Staff Selections

He will select right type of Instructors and will create facilities and atmosphere conducive for the improvement of Instructional standard. He will also raise and develop a system of lectures delivered by guest speakers considered expert in different fields of studies and utilize their services for the benefit of trainees.

The work of the members of the staff will be assessed on the basis of the results of the examinations of the trainees both in law and drill beside other factors while writing their annual confidential reports.

He will issue such orders and instructions to the staff and trainees as may be considered necessary for the pursuit of discipline, morale and efficiency. He will also hold frequent meetings for explaining to them the general guidelines of training policy and the measures adopted to meet their personal and departmental needs.

#### d. Controlling

He will ensure that all activities of the \*[College] are conducted with honesty and integrity and directed towards the attainment of the training objectives. In this connection, he will ensure strict compliance of all departmental rules and regulations.

#### e. Coordinating

He will scrutinize and co-ordinate the action of the staff working under him.

---

\* Substituted vide CPO, Pesh: Memo: No. 789/PA/Oprs: dated 06.02.2012.



f. **Budgeting**

He will prepare budget and ensure that the proposed expenditure for the ensuring financial year not only adequately meets the requirements of training but is also made available to him.

g. **Reviewing of Courses**

Through close and constant liaison with the \*[head of district police], he will ascertain the training needs and subject to the approval of Provincial Police Officer, meet those needs by introducing new courses or expanding the existing ones. Constant development and improvement of the curriculum and submitting reports will be his responsibility.

h. **Evaluation**

He will chalk out evaluation system to see that the objectives of the courses are satisfactorily achieved. Will regularly attend parade, pay frequent visits to class rooms, personally supervise the examinations and occasionally inspect the \*[College] premises, hospital, messes canteen, regimental shop, stores, library and godowns etc.

**POWERS OF THE \*[COMMANDANT]**

**Rule No. 13.**

- a. The powers of the \*[Commandant] in respect of punishment, promotions on adhoc basis, leave and rewards shall be similar to that of a \*[Deputy Inspector General of Police of the region and in respect of appointment, similar to DPO.]
- b. In addition to the punishments authorized in the Police Rules, he shall be authorized to inflict the following punishments on the trainees for their misconduct in Police Training \*[College].

- i. Extra Parade.
- ii. Confinement to \*[College] Premises.
- iii. Detention at the \*[College] during recess period or other holidays.
- iv. Extra study period.
- v. Reprimands.

The entry of such punishments will be restricted to their \*[College] sheets only.

- c. He will have the power to return to district any trainee who is guilty of misconduct, gross carelessness, negligence in the pursuit of his training or whose work shows that he is unlikely to pass the final examination.
- d. He shall have the power to order the postings of the staff within the Institution.
- e. He shall have the power to return to district any \*[junior rank officer as defined

\* Substituted vide CPO, Pesh: Memo: No. 789/PA/Oprs: dated 06.02.2012.

Ops: dated 06.02.20

in the Police Order, 2002, (Order No. 22 of 2002)] who is no longer considered useful to the Institution with intimation to the \*[Provincial Police Officer, Khyber Pakhtunkhwa] Peshawar or any other authorized officer.

- f. He shall be empowered to place any locality out of bounds to the trainees and staff.
- g. During holidays he shall have powers to detain at the College for a further period of instructions any trainees who in his opinion is weak in law and drill subjects as well as the staff and the trainees necessary for the maintenance of guards and other duties.
- h. \*[The Commandant has the power to immediately repatriate any staff member to his district/ unit, if his conduct and performance is not upto the mark.]

### **DUTIES AND POWERS OF THE \*[DEPUTY COMMANDANT]**

#### **Rule No. 14.**

- (i) \*[He will be second in command and assist the Commandant in all matters relating to administration, control, training, working and running of the College.
- (ii) He would exercise all the powers of SP in respect of disciplinary issues, as provided in the police rules or any other rules for the time being in force.
- (iii) He will supervise the daily working of the lines, law and Drill staff. He will take care of the discipline.]

### **\*[DUTIES OF THE DSP ADMINISTRATION]**

#### **Rule No. 14A**

- i. He will make sure that the daily training programmes are run according to the manual and daily time table.
- ii. He will inspect all the lines management twice a week and report any deficiency and irregularity if any.
- iii. He will make sure to implement all orders pertaining to lines, discipline, security and cleanliness of the college.
- iv. He will supervise the work of instructors.]

### **DUTIES OF THE CHIEF LAW INSTRUCTOR**

#### **Rule No. 14B**

The duties of the Chief Law Instructor shall be:

1. To assist the Commandant in the preparation and revision of all programs of academic instructions.

---

\* Substituted vide CPO, Pesh: Memo: No. 789/PA/Oprs: dated 06.02.2012.



2. To supervise the work of Law Instructors and ensure that teaching process is conducted on correct lines. For this purpose he will check the note books of trainees informally chat with them and occasionally sit in class rooms to satisfy himself that the Instructors are fully prepared in their subjects and follow correct lesson plans and make effective use of instructional techniques.
3. To make the new Instructor to understand the limit and extent of his responsibility and the nature of his job. Assist him through personal guidance, discussions and provision of reading materiel in preparing his subject documents and lesson plans.
4. To hold fruitful discussions with the members of the staff, clear their thinking, remove their doubts and give extra guidance regarding instructional work. During preparation period, he will not fail to point out any mistake or shortcomings noticed by him during his inspection of the work of the staff.
5. \*[Deleted as these responsibilities given to Controller of Examination.]
6. To submit a detailed report on the course concluded mentioning interalia, whether the desired out-come of learning has taken place and effective use was made of all available resources. Special mention will be made on the contents of the course, grades of the trainees with special reference to their suitability for nature of the jobs, personality, knowledge, resourcefulness, desire to teach and ability to communicate.
7. To do himself such tuitional work as is assigned to him and in that capacity will make efforts to set an example for others to follow.
8. To bring to the notice of the \*[Commandant] any case of mis-conduct or matters pertaining to discipline of the instructors as well as the trainees.

**\*[DUTIES OF THE CONTROLLER OF EXAMINATION.]**

**Rule No. 14C**

There will be a controller of examination at PTC Hangu. His responsibilities shall be as under:

- a. He shall be responsible to set the question papers. For every written examination to be held in the College, the Controller of Examinations will make suitable arrangements to hold it.
- b. Every answer paper given to the examinee will be dated and sealed with a stamp bearing the signature of the Controller of Examinations. This seal will remain in the personal custody of the Controller of Examinations.
- c. The initial of an examiner be taken on answer papers as a measure to avoid cheating.
- d. The Controller of Examinations will be in-charge of the examinations of all subjects. He will be assisted by the staff members selected for invigilation duties. No other member of the staff will be allowed to enter the examination hall during the course of examination, except on urgent business after seeking permission.
- e. The question papers, prepared by the examiners, will be distributed personally by them or by the controller of Examinations.

---

\* Substituted vide CPO, Pesh: Memo: No. 789/PA/Oprs: dated 06.02.2012.



- f. The question papers prepared by the Controller of Examinations will remain in his personal custody till they are distributed to the examinees in the examination hall.
- g. Answer papers will be collected by the invigilators and immediately handed over to the Controller of Examinations.
- h. In case of Board subjects the answer books shall be handed over to the examiner if present.
- i. The answer papers of the trainees shall be kept by the Controller of Examinations in his personal custody in a locked box in between the time he receives them in the hall and the time when they are finally marked by the group of examiners. Other members of the staff shall on no account be entrusted with or have access to the answer papers during this period.
- j. He will be responsible to admit eligible candidates in the examination.
- k. He will present the question papers in safe and secured manner in the examination hall.
- l. In consultation with CLI, he will nominate the invigilation staff.
- m. In consultation with CLI, he will form team (s) for checking of papers and for this purpose he may, with the approval of the Commandant, call instructors from RTW Kohat or RTW Manshra.
- n. He will be responsible for compilation of merit based results.
- o. He will be responsible to present the results or any related document (s) to the Commandant or any officer nominated by the Commandant.
- p. He will be responsible to dispatch the results after the signature of the Commandant. He will be responsible to maintain computerized of all exams/results.
- q. The answer papers will be destroyed after every two years.]

### DUTIES OF RESERVE INSPECTOR.

#### Rule No. 15.

- a. He will daily visit the hospital, barracks, quarters, all \*[College] buildings and premises to see that they are clean and tidy.
- b. He will tell off guards and attend roll calls daily.
- c. He will bring in to the notice of \*[Commandant] matters in which he considered that any specific orders should be issued.
- d. He will see that the duties allotted to members of the administrative staff and class IV servants are properly and efficiently carried out.
- e. He will attend orderly room regularly and inspect all \*[College] guards at least twice a week by night after zero hours and at day time as well.

---

\* Substituted vide CPO. Pesh: Memo: No. 789/PA/Oprs: dated 06.02.2012.



- f. He will personally inspect all men reporting sick when they fall in for morning and evening parade.
- g. He will report matters relating to administration of the Police Training \*[College] to the Commandant.
- h. He should also see that orders made by the \*[Commandant] in respect of any matter are carried out properly by the persons concerned.
- i. All other duties mentioned in the Punjab Police Rules 17.2.

### DUTIES OF CHIEF DRILL INSTRUCTOR.

#### Rule No. 16.

The chief Drill Instructor will:-

- a. Supervise the instructions in drill, \*[weapon handling, firing] and in physical training and see that the attendance of all ranks is regular.
- b. That the drill is being carried-out according to the prescribed regulations and that all ranks are taught to clothe themselves smartly and neatly. He shall command the parade and give special instructions under the control of the \*[Commandant].
- b. Make the parade statement daily and present to the \*[Commandant] or other senior officer on parade and see that the absentees are noted therein.
- c. Supervise the work of the drill staff and see that discipline is maintained amongst the trainees and staff.
- d. See that all bugle calls are sounded punctually.
- e. Conduct personally all the daily drill preparation parade.
- f. Arrange all drill demonstrations and tactical schemes.
- g. Prepare with the approval of the \*[Commandant] daily, weekly and monthly time-tables according to the syllabus.
- h. Scrutinize all lesson plans and ensure that they are being followed minutely by all the instructors. He will supervise all long and short range firing.
- i. Report all breaches of discipline and misconduct during parade and PT hours to the \*[Commandant].
- j. Maintain record of all trainees showing their progress, punctuality in attendance on parade and PT behavior on the parade ground, initiative and leadership.
- k. Supervise and organize all sports, games and PT displays.
- l. Organize and supervise all authorized social works.
- m. Attend all firing on the miniature, long rifle and other weapon ranges.
- n. Conduct tests in such drill subjects as are assigned to him according to rule 128 of the manual.
- o. Maintain a record of the working and instructional ability of all drill instructors and ensure that harsh and bullying methods are not employed by them.
- p. Perform such other duties as may be assigned to him by the \*[Commandant].

---

\* Substituted vide CPO, Pesh: Memo: No. 789/PA/Oprs: dated 06.02.2012.

## DUTIES OF THE LINES OFFICER.

### Rule No. 17.

The Lines Officer will generally perform all the duties that are assigned to his counterpart in the district Police Lines.

- a. He will also maintain record of all the furniture beds and boxes.
- b. He will be responsible for the correct up keep and maintenance of all the equipment arms and ammunition on charge of the \*[College].
- c. Supervise the cleanliness of the \*[College] premises.
- d. Inspect the buildings, the lines attached to the College and the sanitary arrangements daily.
- e. Supervise the work of malies and organize vegetable gardens and other cultivated lands.
- f. Be responsible for the maintenance of all Government vehicles on charge in the \*[College] and their logbooks.
- g. To supervise the disbursement of money received from the account branch and to act as a treasurer of the Regimental Fund, \*[College] funds and such other funds as the \*[Commandant] may direct.
- h. To supervise irrigation and other water arrangements.
- i. To see that all animals on charge of the \*[College] are properly looked after.
- j. To look after welfare of the men in hospital and to arrange for their special diet if necessary.
- k. And to perform such other duties as the \*[Commandant] may direct.
- l. All duties mentioned in Police Rules 17.03.

---

\* Substituted vide CPO, Pesh: Memo: No. 789/PA/Oprs: dated 06.02.2012.



## DUTIES OF LINES MUHARRIR.

### Rule No. 18.

\*[Lines Muharrir will normally be of the rank of ASI. His responsibilities shall be as provided in the Police Rules. He will be assisted by an additional Muharrir and Assistant Muharrirs of the rank of HC and LHC respectively. Besides the above staff, more assistant can be posted on the basis of workload.]

\*[There will be the following other positions in the lines management. They would be taking care of their responsibilities as mentioned in the Police Rules, Standing Orders issued by the PPO and standing orders issued by the Commandant, PTC from time to time.

1. In-charge Kot.
2. Armourer
3. In-charge General Godown.
4. In-charge Regimental Store
5. In-charge Regimental Shop.
6. In-charge Clothing Godown
7. In-charge Hostel No. 02
8. In-charge Services Block
9. Mess Secretary
10. Mess Manager
11. Mess Recovery Managers
12. In-charge Canteen
13. MTO
14. Tear Gas Instructor

The heads of these branches would not be selected out of the cadet law Instructors. The tenure of these positions would not be more than one year.]

## DUTIES OF LINES MUHARRIR.

### Rule No. 19.

\*[Deleted, as it has been mentioned in Rule No. 18.]

## DUTIES OF KOT HEAD CONSTABLE.

### Rule No. 20.

\*[Deleted, as it has been mentioned in Rule No. 18.]

---

\* Substituted vide CPO, Pesh: Memo: No. 789/PA/Oprs: dated 06.02.2012.

## DUTIES OF ARMOURER

### Rule No. 21

\*[Deleted, as it has been mentioned in Rule No. 18.]

## DUTIES OF TEAR GAS INSTRUCTOR.

### Rule No. 22.

\*[Deleted, as it has been mentioned in Rule No. 18.]

## DUTY OFFICER

### Rule No. 23.

\*[Deleted from here, as duties of the Duty Officer mentioned in Rule No. 139.]

## DUTIES OF ASSISTANT DUTY OFFICER.

### Rule No. 24.

\*[Deleted. There are 02 DO's at a time now and their responsibilities mentioned in Rule No. 139.]

## ASSISTANT CHIEF DRILL INSTRUCTOR.

### Rule No. 25.

Assistant Drill Instructor will assist the Chief Drill Instructor and will look after his duties in his absence, besides other duties assigned to him by the \*[Commandant].

---

\* Substituted vide CPO, Pesh: Memo: No. 789/PA/Oprs: dated 06.02.2012.



## CHAPTER 4.

### MISCELLANEOUS

#### COMPANY COMMANDERS.

##### Rule No. 26.

Each Company will be under the control of an officer designated as Company Commander. In addition to the instructional duties, the Company Commander will perform the following duties:-

- i. Company Commanders will hold kit inspections as the trainees arrive. Shortage and ill-fitting will be brought into the notice of the \*[Commandant through proper channel] for onward submission to the \*[Provincial Police Officer, Khyber Pakhtunkhwa]. or authorized officer.
- ii. \*[Any trainee of their company who is required to be rewarded or who have any request, which can be disposed of by the Commandant only, will be forwarded to him through proper channel.
- iii. The company commander will be responsible to report disciplinary issues to the officers authorized by the Commandant].
- iv. They will be responsible for the discipline and progress in law and drill subjects of the trainees of, their respective companies.
- v. In order to keep a check on the progress of trainees in their companies they will maintain companies register. This register will contain details of each trainees' tribe, place of residence, note-worthy relations etc. his conduct, ability to play games and his progress both in drill and educational subjects. As ordered from time-to-time by the \*[Commandant], trainees who are particularly backward will be placed on "SPECIAL REPORT" Such trainees will be very carefully watched both by drill and law instructors and efforts would be made to improve their deficiencies and make them suitable for the Department. \* [...]
- vi. Company Commanders will be empowered to grant short permission up to evening roll call during day time \*[and emergency leave upto three days] and for this purpose they will keep an up to date record of their outgoing trainees. \* [...]. They will ensure that the trainees so permitted are properly and neatly dressed.

---

\* Substituted vide CPO, Pesh: Memo: No. 789/PA/Oprs: dated 06.02.2012.

- vii. \*[The company commander, in form 26(vii), will forward the leave request of a trainee, without causing any inconvenience or delay, to the authority concerned.]
- viii. \*[All the Company Commanders of the companies and their Assistants shall invariably associate themselves with sports and social work of their respective companies on daily basis.]

## COMPANY COLOUR.

### Rule No. 27.

\*[All the companies would have colours, symbols and motos.]

## FORMATION OF CLASS AND SQUAD.

### Rule No. 28.

Each company shall be subdivided into classes for the purpose of academic instructions and into squads for drill instructions. The academic class shall not be more than twenty-five trainees while the drill squads shall not exceed twenty-one trainees. A law instructor shall be responsible for his subject for each class while a drill instructor shall be responsible for his squad. The Law instructor will, however, not teach all the law subjects to one particular class but will teach one subject to the classes allotted to him. In the case of the Drill Instructor he may teach all the drill and P.T subjects to his Squad, if he is so qualified. Otherwise instructors specialized in those particular subjects shall be detailed for this purpose.

## OFFICIAL OF THE COMPANY.

### Rule No. 29.

\*[The Company Commander shall be assisted by two officers; one would be called Assistant Company Commander and other company Havaladar.

There will be one monitor in each law class only. He will be posted for one month.

- a. Class monitor will be responsible for maintenance of the attendance register submission of daily statement reader to the CLI and cleanliness of the class rooms.
- b. He will also be responsible to get the lights and fans off and the doors shut after class.
- c. He will be responsible to look after the class affairs according to the directions of the instructors.
- d. He shall be responsible to see that the furniture and class room are clean before

\* Substituted vide CPO, Pesh: Memo: No. 789/PA/Oprs: dated 06.02.2012.



- the daily work begins.
- e. He shall be responsible for the discipline of the class in the class room during the class periods in the absence of instructor and outside till the trainee reach their respective barracks in orderly manner.]

### REGISTER AND RECORDS.

#### Rule No. 30.

- (a) \*[Computerized record of all trainees shall be maintained in record office headed by a law instructor.
- (b) Every company commander shall maintain a register in form 30(b) for in-service and probationer class courses and in form 30 (b) (i) for recruit constables showing all the detail about the trainees in the given columns.
- (c) He shall maintain a register, showing all the Government property on charge of the company, in form 5-16(1) police rules 1934.]

### DUTIES OF ASSISTANT COMPANY COMMANDERS.

#### Rule No. 31.

Every Company Commander shall have one or more Assistant Company Commanders to assist him in his duties as Company Commander.

The second in command shall:

- a. In the absence of the Company Commander perform all his duties.
- b. Perform such duties as may be assigned to him by his Company Commander and officers senior to him.
- c. Take part in all sports and games of the Company.
- d. \*[deleted]
- e. Carry out periodical physical checks of all Government Stores on charge with the company.
- f. Report all cases of breaches of discipline coming to his notice.
- g. Under the supervision of the Company Commander be responsible for maintenance of all registers and records to be maintained by the company.
- h. Hold roll call of the company and tell off all duties and the next day's program to the trainees.

---

\* Substituted vide CPO, Pesh: Memo: No. 789/PA/Oprs: dated 06.02.2012.

## DUTIES OF COMPANY HEAD CONSTABLE (HAVALDAR)

### Rule No. 32.

The Company Havaldar shall be:

- a. Responsible to the Company Commander for the discipline and good turnout of the men of his company.
- b. Bring immediately to the notice of the Company Commander all cases of absence and illness in his company.
- c. Supervise all social work of his men.
- d. Ensure the proper use and maintenance of all arms, equipment, bed and boxes and accoutrement of social work, all other Government property and shall report immediately the loss or damage of any property to the company commander.
- e. \*[deleted]
- f. Supervise the sanitation of the area assigned to the company and be personally responsible for its cleanliness.
- g. Be present at Arms cleaning Parade for and shall ensure that all arms of the company are properly cleaned.
- h. Shall in the absence of the Assistant Company Commander perform his duties.
- i. Perform such other duties as may be assigned to him in respect of his company.
- j. Participate in games and sports with the men of his company during competition.
- k. Perform such instructional duties as may be assigned to him.

## DUTIES OF INSTRUCTOR.

### Rule No. 33.

- a. With the concurrence of the \*[Commandant], Instructors of both Law and the Drill attached to the company shall perform such instructional duties as may be assigned to them, by the Chief Law and Chief Drill Instructors according to syllabus prescribed for such course.
- b. Instructors shall at all times carefully watch the progress of the trainees and shall bring to the notice of the Chief Instructors concerned and the Company Commander, the trainees requiring extra attention or who is not proving to be a willing worker or otherwise lagging behind the rest of the class or squad.
- c. Instructor shall immediately bring in to the notice of the Chief Law Instructor of any irregularity in the attendance in class. For this purpose Law Instructors shall maintain a class attendance register in the prescribed form.
- d. It shall be the duty of all instructors to bring into the notice of the Company Commander or a senior officer any breach of the rules of the College or misconduct of

\* Substituted vide CPO, Pesh: Memo: No. 789/PA/Oprs: dated 06.02.2012.



any trainee which may come to his notice.

- e. They shall always be dressed in the prescribed uniform while imparting instructions.
- f. They shall instruct strictly according to the syllabus, time table and lesson plan approved by the \*[CLI under the guidance of the Commandant].

### DUTIES OF COMPANY MONITOR.

#### Rule No. 34.

\*[deleted]

### DUTIES OF CLASS ROOM MONITOR.

#### Rule No. 35.

\*[Deleted as it has already been included in Rule No. 29]

### GAMES.

#### Rule No. 36.

Athletics and games of all kind shall form a regular part of the training for all ranks at the College. The Commandant shall detail a member of the staff as sports officer. He will be responsible for the maintenance and replacement of sports equipment. Company Commanders will form teams of their companies in respect of each game which will participate in \*[Company] Competition on the conclusion of each term. Athletics and games will be held daily and competition will be held \*[on quarterly] basis. Trainees participating in games and athletics will secure marks for themselves as well as for their respective companies. Award of trophy to best sportsmen will be declared on conclusion of games in each term.

\*[.....]

### DUTIES OF THE S.H.O. MODEL POLICE STATION.

#### Rule No.37.

There will be a Model Police Station in which trainees will be trained in working of the Police Station. The training in Model Police Station will be supervised by P.P.W. Inspector. The Police Station will be provided with an S.H.O from the Upper \*[College] Course. One A.S.I. from Intermediate \*[College] Course and a Muharrir from the

\* Substituted vide CPO, Pesh: Memo: No. 789/PA/Oprs: dated 06.02.2012.

Lower \*[College] Course. Senior literate recruit will also be provided as Madad Muharrir from duty company.\*[All the staff detailed at the police station would be changed daily. DSP/Insp: Legal would be responsible to assign the investigation of a criminal case to the staff and guide them how to do it.

The S.H.O will be responsible to complete the investigation within 3 to 6 days and submit final report to the Inspector P.P.W. the Inspector P.P.W will forward the case files to the scrutiny officer designated by the DSP (L) /CLI . The scrutiny officer will evaluate, submit report to the DSP(L)/ CLI within three days.]

Inspector P.P.W. will ensure that the trainee staff put on Police Station duties is doing their duties properly according to law and Police Rules. Apart from the routine duties of the Police Station mentioned in Police Rules, he will arrange a mock registration of cases of different crimes in the Model Police Station and the SHO will conduct its investigation making all entries in the relevant registers pertaining to that case in Model Police Station himself and through his Muharrir. After the completion of investigation the Inspector PPW will check the case file and shall see that all other related actions for the prevention of such crimes have been taken by the SHO. He will also comment regarding the standard of investigation and will also point out the omissions made by the SHO for completion. He shall also see that the scientific methods in that particular crime for its detection have been fully applied by the investigating officer.

\*[.....]

### DUTIES OF STATION CLERK OF MODEL POLICE STATION.

#### Rule No. 38.

The station clerk of the model police station shall be a \*[ASI] from law staff and his duties shall be:

- i. He will train the trainees posted as Muharrir.
  - ii. He will perform all the duties strictly in accordance with Police Rules.
- He will play his role in the investigation assigned by the inspector P.P.W to the trainee S.H.O and his staff.

### DUTIES OF OFFICER INCHARGE TRAINING AIDS.

#### Rule No. 39.

The officer In-charge training aids shall be an upper subordinate law instructor. It will be his duty to:

- a. Maintain the register in the form prescribed for all training aids in his charge.
- b. To look after and maintain in a proper condition all such aids.
- c. Maintain a register of temporary issues.

\* Substituted vide CPO, Pesh: Memo: No. 789/PA/Oprs: dated 06.02.2012.



- d. Operate any apparatus when required to do so for demonstration or other purposes.

Follow the standing order issued by the \*[Commandant] regarding the use of these aids and their proper maintenance. These aids will be fully utilized for training purpose and shall ensure the availability of the requisite material.

### DUTIES OF PHOTOGRAPHER.

#### Rule No. 40.

\*[Deleted]

### DUTIES OF INCHARGE LIBRARY

#### Rule No. 41.

There shall be a full time qualified Librarian. Till such post is sanctioned by the Government an upper subordinate from the law staff will work as Librarian. \*[He shall maintain a computerized record of the collections.] \*[...] In case, any book is lost or is not returned by the borrower and if the In-charge fails to furnish any satisfactory explanation, he will be dealt with departmentally regardless of the recovery of the cost of the missing books from him. The \*[Commandant] shall see that books are available to the trainees and staff on their demand. At no cost any book or journals of any kind will be issued from the library to the outsiders, except with the permission of the \*[Commandant]. The outsider will deposit double the amount of the cost of the book as security which will be returned to him as soon as he returns the same within the prescribed period.

\*[CLI shall also be responsible for the proper maintenance of the college museum.]

### DUTIES OF INCHARGE P.T.C EQUIPMENT & MUSKETRY STORES.

#### Rule No. 42.

\*[Deleted this duty assigned to the Controller of Examinations]

---

\* Substituted vide CPO, Pesh: Memo: No. 789/PA/Oprs: dated 06.02.2012.

## DUTIES OF INCHARGE REGIMENTAL STORE.

### Rule No. 43.

\*[Deleted, already covered in Rule No. 18]

### \*[INCHARGE ACADEMIC BLOCK.]

### Rule No.44.

\*[There will be a junior officer designated by the CLI as In-charge of the academic block. This will be his additional responsibility, which will include.

- (a) To keep an account of all the Government property present in the block and ensure its proper upkeep and maintenance. All to be entered in a register attested by the CLI.
- (b) He shall be responsible for the cleanliness and maintenance of all the offices class rooms, wash rooms, corridors etc.
- (c) Staff room shall be maintained in which facilities will be provided for the meeting of members of the staff. The proper maintenance of this room shall be the responsibility of the In-charge academic block.

There will be a staff officer preferably of the rank of Inspector. His duties will be:

- a. To assist the Chief Law Instructor in allotment of periods to Law Instructors and preparation of time table according to syllabi of different classes.
- b. To attend the preparation period for Law Instructors and to see that the Instructors are well prepared before going to their respective classes.
- c. To see that the text books are available both to the staff and trainees.]

## STAFF ROOM.

### Rule No. 45.

\*[Deleted, as it has been covered in the last aforementioned rule.]

## POLICE MESSES.

### Rule No. 46.

\*[Deleted]

\* Substituted vide CPO, Pesh: Memo: No. 789/PA/Oprs: dated 06.02.2012.



**HOSPITAL.****Rule No. 47.**

Adequate arrangements for the hospitalization of serious cases requiring medical attention shall be provided. An experienced Medical Officer of the Medical Department shall be in attendance.

If possible, welfare facilities will be provided for the families of the hospital staff.

**BAND.****Rule No. 48.**

\*[There will be a band at PTC as per sanctioned strength. It would be provided to the staff and private persons on the occasion of wedding or any other ceremony. The rates to be charged for this purpose would be as under which may be changed by Commandant from time to time].

- (1) For staff member Rs.1000.
- (1) For private person Rs.5000.

50% of the amount will be deposited in the band fund and 50% to be given to the band staff. Transport will be provided by the person requesting for provision of band.

**CONTRACTORS.****Rule No. 49.**

The \*[Commandant] may enter into contracts with interested parties for the supply of food stuffs and other commodities of daily consumption \*[to the mess, lease out canteen] and for the services of Dhobi, Cobblers, Barbers etc. All contractors shall be required to maintain their premises in a clean and orderly manner and shall be subject to all directions issued by the \*[Commandant]. No member of the staff and no trainee shall be permitted to exercise direct authority over the contractors or their representatives. All complaints regarding the work of the contractors shall be made through proper channel to the \*[Commandant]. The conduct of the contractors shall be supervised by the Reserve Inspector \*[through an in-charge officer] and he will \*[...] submit his report about an irregularity.

---

\* Substituted vide CPO, Pesh: Memo: No. 789/PA/Oprs: dated 06.02.2012.

## REPAIRS TO BUILDINGS.

### Rule No. 50.

\*[Deleted, as this is already done according to the Police Rules.]

## ALLOTMENT OF FAMILY QUARTERS.

### Rule No. 51.

- a. The allocation of family quarters shall be done by the Commandant. A waiting list shall be maintained in the office of the Commandant in a register prescribed by the Police Rules \*[3-20].
- b. The Commandant shall draw up standing orders for regulating the operation of these rules.
- c. No trainee or recruit shall be provided with family accommodation.
- d. \*[All sort of maintenance would be the responsibility of the occupant.]
- e. \*[Family quarters will be allotted for maximum period of 3 to 5 years.]

## ELECTRICITY, GAS AND WATER IN FAMILY QUARTERS.

### Rule No. 52.

\*[Deleted, as it is a routine matter and no need to mention specially.]

## PROVISION OF ELECTRIC LIGHTS AND FANS IN CLASS ROOMS.

### Rule No. 53.

\*[Deleted, as it is a routine matter and no need to mention specially.]

## CLEANLINESS OF POLICE BUILDINGS AND QUARTERS

### Rule No. 54.

The occupants of Government quarters shall be responsible for the cleanliness of buildings, its premises and the area adjacent to it. The cleanliness shall be of a standard to the satisfaction of the \*[Commandant]. Persons not maintaining the required standard of cleanliness will be directed to vacate the buildings.

\* Substituted vide CPO, Pesh: Memo: No. 789/PA/Oprs: dated 06.02.2012.



## DAMAGE TO BUILDINGS.

### Rule No. 55.

The cost of all willful damage or damage by negligence on the part of the occupants or their families shall be recovered from the occupant. The \*[Commandant] shall be the final judge to determine whether the damage has been caused by neglect or otherwise.

## \*[MISUSE OF FACILITY ]

### Rule No.56.

\*[An official found guilty of the misuse of a facility such as illegal connection of electricity could be ordered to vacate the quarter in a week time by the Commandant. **Unfriendly neighbor:** If the occupant or his family is considered unfriendly by his neighbor, he would face an enquiry and if charge stands proved would be asked to vacate the residence in a week time positively.]

## RANGES

### Rule No.57.

\*[Ranges of the approved pattern shall be provided to the different trainees as per requirement of their syllabus.]

## METHOD TO ESTIMATE ACCOMODATION.

### Rule No. 58.

While estimating accommodations required for class rooms, barracks, messes and assembly halls, care should be taken to make provision for ample supply of natural light and fresh air.

## COLLEGE GARDENS, SPORTS AND PARADE GROUNDS ETC.

### Rule No. 59.

It shall be the constant endeavor of the \*[Commandant] to improve the premises of the Institution by providing vegetable gardens, flower beds, lawns orchards and

\* Substituted vide CPO, Pesh: Memo: No. 789/PA/Oprs: dated 06.02.2012.

shady trees around the parade and sports grounds. It shall be considered a breach of discipline on the part of any trainee or member of the staff, if found damaging or failing to maintain in proper condition the vegetable gardens, flowers beds, lawns and trees etc. Vegetable shall be sold to the staff member and messes on concessional rates. \*[…]

### KIT INSPECTION.

#### Rule No. 60.

\*[Deleted as already mentioned in rule No.26.]

### REPAIR AND ALTERNATION OF KITS BY COLLEGE TAILORS.

#### Rule No. 61.

The repair of uniform of the members of the staff shall be carried out by the Tailor Contractor. Fitting of uniform of all trainees and defects if noticed during first kit inspection will immediately be intimated to their respective \*[selecting authority] who will detail Tailor Master from their district for the purpose. This Institution may, however, issue uniform articles to the trainees on payment.

### MUFTI DRESS.

#### Rule No. 62.

Trainees should be bound to wear the mufti dress specified by the \*[Commandant].



**TRAINING AIDS EQUIPMENTS.****Rule No. 63.**

All training aid equipment's after being surveyed and entered in Lines register shall be transferred to the Chief Law Instructor who shall be responsible for their proper storage and maintenance through the assistance of an Upper Subordinate of the Law Staff. A register in form 5-16 (1) of Police Rules shall be maintained.

**BEDS (CHARPAES)****Rule No. 64.**

The relevant Police Rules shall be followed strictly. The specified number of beds shall be issued to each company \*[from the General Godowns] and their maintenance shall be the responsibility of the Company Commander. Issue of the beds to the Lower subordinate staff shall be the responsibility of Reserve Inspector.

**\*[MULTIMEDIA & COMPUTERS].****Rule No. 65.**

\*[The above equipment on receipt shall be inspected and subsequently recorded in the lines/stores registers. The In-charge Computer Laboratory will be responsible for its storage and maintenance.]

**ARMS AND AMMUNITION.****Rule No. 66.**

\*[Deleted as already mentioned in rule No. 18.]

**DEMONSTRATION PURPOSES.****Rule No. 67.**

\*[The scale in respect of demonstration purposes of arms and ammunition shall be authorized by the Provincial Police Officer. The authorized service stocks shall be notified by the Provincial Police Officer.]

---

\*Substituted vide CPO, Pesh: Memo: No. 789/PA/Oprs: dated 06.02.2012.

## PRACTICE STOCK AMMUNITION.

### Rule No. 68.

\*[The practice stock of various ammunition shall be maintained at the institution for meeting their requirements of staff and trainees. The ammunition required for practice and final examinations will be provided by the centralized Kot, CPO Peshawar. The cost of practice ammunition, in case of trainees of the other provinces and formation, shall be included in the training charges referred to in rule No. 4(i) of the Manual.]

## DISTRICTS TO PROVIDE PRACTICE AMMUNITION.

### Rule No. 69.

\*[Not in practice deleted.]

## MUSKETRY EQUIPMENTS.

### Rule No. 70.

\*[Not in practice deleted.]

## INDIVIDUAL RESPONSIBILITY OF ARMS.

### Rule No. 71.

\*[Not in practice deleted.]

## GAS EQUIPMENT-INDENT OF.

### Rule No. 72.

The requirements of Gas equipment's of districts of the Province shall be indented for through the \*[Commandant] in accordance with the standing orders of the \*[Provincial Police Officer], on the scale authorized in those orders. The \*[Commandant] shall keep himself in contact with the manufactures and contractors in order to know the type and function wise quality of the respective type of gas required to be utilized in Police Practical Work. If some new invention in the gas equipment is made by the manufacturer, the \*[Commandant] must practice its utility and if found useful, shall recommend its purchase to the \*[Provincial Police Officer], mentioning its quality-wise particulars.

\* Substituted vide CPO, Pesh: Memo: No. 789/PA/Oprs: dated 06.02.2012.



## STORAGE OF GAS EQUIPMENTS.

### Rule No. 73.

The storage of gas equipment at the training Institution shall be in a room having free ingress of air.

## DISTRIBUTION OF GAS EQUIPMENTS.

### Rule No. 74.

Distribution and reserve stock of gas equipment's at the scale authorized by \*[Provincial Police Officer], shall be maintained at the Institution.

## MOTOR TRANSPORT.

### Rule No. 75.

Motor transport shall be kept under the charge of the \*[rank of ASI/SI] who will be called Motor Transport Officer. The Motor Transport Officer must have at least a driving license for light transport vehicles. He will maintain and use the transport according to the \*[relevant Standing Order]. The Institution shall be provided with such number of jeeps, staff cars and heavy transport as may be ordered by the \*[Provincial Police Officer], according to the training needs.

One transport should be given duty order for the administration duties of the Police Training \*[College] which also includes the carriage of \*[College] going children of the staff to the \*[College] and back.

## DUTIES OF DRIVERS.

### Rule No. 76.

Their duties will be governed by the standing orders. When not employed on driving they shall perform such duties as may be directed by the \*[Commandant]. They shall also participate in annual musketry course and shall attend Parade for musketry training.

## USE OF VEHICLES.

### Rule No. 77.

Vehicles will be used under the authority of the \*[Commandant] for demonstration purposes, transportation of trainees to scene of exercise, carriage of arms, equipment's and other Government Stores etc.

## RECESS.

### Rule No. 78.

There shall be a recess of (10) ten days at the end of each term.

## DUTIES OF STAFF DURING THE RECESS.

### Rule No. 79.

- a. The \*[Commandant] shall make such arrangements as may be necessary for the performance of duties during the recess and for the protection of government property in \*[College]. For this purpose, he may detain any number of trainees and staff.
- b. Such members of the staff who are not required for duty may be allowed station leave. It must be understood that the members of the staff cannot claim the vacations as a matter of right and must be prepared for such work as may be given to them during the recess.



## LEAVE TO STAFF.

### Rule No. 80.

In addition to the recess, all members of the staff shall be permitted to avail the existing facilities in respect of casual leave. Earned leave should not be considered during deputation period at Police Training \*[College] until the vacancy for leave reserve is sanctioned. In case of prolonged illness which renders the instructor incapable to attend the classes, his substitute will be asked for and the ailing officer will be reverted back to his district.

## LEAVE TO TRAINEES.

### Rule No. 81.

In rare cases the trainees will be permitted to avail of leave. Casual leave to trainees shall only be granted by the \*[officers authorized as per rules].

(Note) Absence from training program in any manner i.e.

- a. Leave of kind due
- b. Medical leave
- c. Absence on duty at the ratio of three days per month for the whole period specified for particular course will render a trainee disqualified to appear in the final test.

The \*[Commandant] may detain such trainees for the next term or revert him to the district/unit with the recommendation to be re-selected \*[in future, if deemed fit]. Such detention or reselection will not increase the number of allocated seats of the districts/unit for that particular course. It would be in the interest of the trainees that the \*[head of districts/units] will provide to \*[Legal Branch] a list of trainees selected for Lower and other senior courses directing them to pool all the cases for their evidence in the dates \*[falling] during recess which according to \*[College] program are:-

- |      |                        |    |                            |
|------|------------------------|----|----------------------------|
| i.   | 21 <sup>st</sup> March | to | 31 <sup>st</sup> March     |
| ii.  | 21 <sup>st</sup> June  | to | 30 <sup>th</sup> June      |
| iii. | 21 <sup>st</sup> Sept: | to | 30 <sup>th</sup> September |
| iv.  | 21 <sup>st</sup> Dec:  | to | 31 <sup>st</sup> December  |

Summons issued for such cases be sent to this Institution for witness. The \*[head of districts/units] may request the Session Judge of their districts in Police Magistracy meeting for public interest. The \*[Legal Branch] must see that provision Qanoon-e-Shahadat (Order No. 10 of 1984)] are availed of, and shall be governed by the trainee fall within the purview of this section.

\* Substituted vide CPO, Pesh: Memo: No. 789/PA/Opr- [Signature] Officer].  
 Date: dated 06.02.2012.

## LEAVE TO STAFF.

### Rule No. 80.

In addition to the recess, all members of the staff shall be permitted to avail the existing facilities in respect of casual leave. Earned leave should not be considered during deputation period at Police Training \*[College] until the vacancy for leave reserve is sanctioned. In case of prolonged illness which renders the instructor incapable to attend the classes, his substitute will be asked for and the ailing officer will be reverted back to his district.

## LEAVE TO TRAINEES.

### Rule No. 81.

In rare cases the trainees will be permitted to avail of leave. Casual leave to trainees shall only be granted by the \*[officers authorized as per rules].

(Note) Absence from training program in any manner i.e.

- a. Leave of kind due
- b. Medical leave
- c. Absence on duty at the ratio of three days per month for the whole period specified for particular course will render a trainee disqualified to appear in the final test.

The \*[Commandant] may detain such trainees for the next term or revert him to the district/unit with the recommendation to be re-selected \*[in future, if deemed fit]. Such detention or reselection will not increase the number of allocated seats of the districts/unit for that particular course. It would be in the interest of the trainees that the \*[head of districts/units] will provide to \*[Legal Branch] a list of trainees selected for Lower and other senior courses directing them to pool all the cases for their evidence in the dates \*[falling] during recess which according to \*[College] program are:-

- |      |                        |    |                            |
|------|------------------------|----|----------------------------|
| i.   | 21 <sup>st</sup> March | to | 31 <sup>st</sup> March     |
| ii.  | 21 <sup>st</sup> June  | to | 30 <sup>th</sup> June      |
| iii. | 21 <sup>st</sup> Sept: | to | 30 <sup>th</sup> September |
| iv.  | 21 <sup>st</sup> Dec:  | to | 31 <sup>st</sup> December  |

Summons issued for such cases be sent to this Institution for service on the witness. The \*[head of districts/units] may request the Session Judge/Additional Session Judge of their districts in Police Magistracy meeting for co-operation in the public interest. The \*[Legal Branch] must see that provision of \*[Article 61 of the Qanoon-e-Shahadat (Order No. 10 of 1984)] are availed of, as most of the evidence of the trainee fall within the purview of this section.

\* Substituted vide CPO, Pesh: Memo: No. 789/PA/Oprs: dated 06.02.2012.



Trainees required in \* [a criminal case/] departmental proceedings, as a accused officer shall not be detained for training till the final decision \*[by the court/competent authority.]

## HOLIDAYS.

### Rule No. 82.

#### i. Closed Holidays.

\*[Sunday] and gazetted holidays shall be observed as full holidays. There will be no \*[College] instructional program on these days except \*[one decided by the Commandant.]

#### ii. Station Leave.

In case of the member of the staff, station leave may be permitted by the competent officer on closed holidays. In case of trainees, short leave by R.I till evening roll call may be allowed during day time after general cleaning program.

## QUARRANTINE

### Rule No. 83.

\*[Not in practice, deleted]

## MEDICAL EXAMINATION.

### Rule No. 84.

The \*[Commandant] may send any trainee for medical examination to the Medical Officer of \*[.....] Hospital if in his opinion, the trainee has physical defect or is physically weak and unable to stand the strain of training. A trainee found unfit by the Medical officer shall be returned to his district by the \*[Commandant] for treatment.

\*[A trainee or recruit presenting medical rest time and again may be referred to a board for examination and check that the rest given by the medical officer is genuine or not.]

## DOCUMENTS OF TRAINEE.

### Rule No. 85.

\*[The following documents shall accompany each trainee:

- (i) Nominal rolls in respect of pre-service trainees in form 85(i).
- (ii) Nominal rolls in respect of in-service trainees in form 85(ii).
- (iii) Medical fitness certificate in respect of vaccination etc.]

## TRANSFER OF PAPERS.

### Rule No. 86.

All correspondence in respect of trainees shall be transferred to their districts to form a part of their Fauji Missal or Service Roll on the completion of their courses \*[on the demand from Districts/Units.]

## STAFF PROMOTION.

### Rule No. 87.

Law and Drill Instructors may be given promotion on their appointment in the \*[College]. Such a promotion shall be of a temporary nature and shall be governed by the instructions issued thereon by the \*[Provincial Police Officer].

\* Substituted vide CPO, Pesh: Memo: No. 789/PA/Oprs: dated 06.02.2012.



## TEMPORARY PROMOTION IN LOCAL VACANCIES.

### Rule No. 88.

The \*[Commandant] may if specially authorized in this behalf make temporary promotion in local vacancies.

## ACCELERATED PROMOTION.

### Rule No. 89.

The criteria governing the selection of best all round trainee under draft PR 13-6 (1), (2) in recruit and Lower \*[College] courses shall be as under.

- i. He shall be best all round in Law and Drill subjects.
- ii. Should bear excellent record for the period of his training.
- iii. Should have taken interest in extracurricular activities.
- iv. The first \*[ten] trainees of recruit and lower \*[College] courses shall be presented to the selection committee for selection of the best all round. The selection committee may recheck the papers of these trainees, and may put questions to them during the interview to ensure a fair selection.
- v. Two hundred (200) marks are placed at the disposal of the selection committee to be awarded to the trainee in written and viva voce test.
- vi. The selection committee shall record its decision pertaining to the declaration of best all round trainee which will be placed at the record of Police training \*[College] Hangu. A copy of the decision will be sent to the District/unit concerned for action.
- vii. (Deleted vide IGP No.7821/E-II dt, 24-04-1985)
- viii. \*[Deleted as it has been clarified in Rule No. 6 of the Manual.]

## QUARTERLY AWARDS.

### Rule No. 90.

To create an incentive the Instructional Staff should be encouraged by grant of rewards for producing good results during the term.

## SPECIAL REWARDS.

### Rule No. 91.

Rewards shall be granted liberally to the members of the staff and students who show initiative, resourcefulness, high standard of morality/commitment and good conduct etc.

## DISCIPLINE.

### Rule No. 92.

The \*[Commandant] shall have full powers to frame standing orders in respect of maintenance of discipline in the barracks, class rooms, messes, sport grounds, Parade grounds and general behavior within the premises of the Institution.

## STAFF AND \*[TRAINEES] RELATIONS.

### Rule No. 93.

- a. It shall be incumbent upon every instructor to inform the \*[Commandant] within a week of the beginning of each term if any trainee, is a near relative of his i.e. father, brother or cousin.
- b. No recruit or trainee shall be deployed by any member of the staff as personal security.
- c. No trainee shall under any circumstances offer any present to any member of the staff. Members of the staff are prohibited from accepting any present from any recruit or trainee, no matter how close his relationship with the trainee may be.
- d. No trainee would be asked to visit instructors in their accommodation at any time.

## OUTSIDE RECOMMENDATION.

### Rule No. 94.

No trainee shall resort to approaches for some favor from the staff member during his training. Those found violating this rule, shall be dealt with severely.



## CHANNEL OF COMMUNICATION.

### Rule No. 95.

The normal channel of communication mentioned in existing rules shall be adhered to and any attempt by any trainee to by-pass the normal channel shall be misconduct. No obstruction should be placed in the way of any trainee who seeks an interview with the higher authorities.

## DESERTION.

### Rule No. 96.

1. Desertion of any recruit or trainee from the Institution is a serious misconduct and is liable for minor/major punishment at the discretion of the \*[Commandant]. Desertion will also relegate the trainee from the course.
2. The respective \*[heads of District/Unit concerned] are responsible to make all out efforts to affect the recoveries from their deserted trainees.
3. The \*[Commandant] has the authority to auction his confiscate his \*[mess security], left at Police Training \*[College] in order to recover outstanding dues of the Police Training \*[College].

## CONDUCT OF HOSPITAL.

### Rule No. 97.

While admitted in Hospital or attending as outdoor patients, clinical discipline shall be maintained by all trainees. Orders and instructions issued by the Medical Officer shall be complied with. Those refusing medical treatment shall be liable to be returned to their districts.

## MEDICAL ATTENDANCE.

### Rule No. 98.

All trainees shall be entitled to free medical attendance at the Institution hospital. Members of the staff shall be entitled to free medical attendance both at the Institution hospital and their residence according to the rules.

---

\* Substituted vide CPO, Pesh: Memo: No. 789/PA/Oprs: dated 06.02.2012.

## PRIVATELY OWNED ARMS.

### Rule No. 99.

No trainee shall bring to the Institution any privately owned licensed arms. However, due to unavoidable circumstances such arms shall be deposited in the Institution Armory immediately on arrival. No arms ammunition shall be kept by any trainee in his barracks or on his person. Arms deposited shall be returned to the depositor on the day he leaves the Institution against a proper receipt. All arms and ammunition deposited shall be accounted for and receipt shall be issued by the Lines Officer. During the course of training such arms deposited in the armory shall not be returned to the trainee except with the permission of the \*[Commandant].

## INDISPOSITION.

### Rule No. 100.

- i. All trainees feeling indisposed shall report to their company commanders and will fall in sick parade in the morning at the bugle call. It will be the responsibility of the Reserve Inspector to ensure that the trainee is not a malingerer. He will enter their names in the sick register and direct the \*[...] \*[Duty] Officer to take them to the hospital for treatment. On other occasions during day and night the indisposition of trainee will immediately be brought to the notice of company commander by company Head Constable who will enter his name in the sick report register for sending him to the hospital for treatment. The Medical Officer will categorise the treatment as A, B and C. Category "A" will connote the simple treatment of trainee's physical problem and no exemption from any sort of training.
- ii. Category "B" will connote treatment given and recommended for exemption of certain type of training.
- iii. Category "C" will connote admission to the hospital for complete treatment. No trainee shall be given rest to avail it in the barracks except blood donors.

## ORDER BOOK.

### Rule No. 101.

An order book in Police Rules form 14.54 (4) shall be maintained in respect of all orders and directions issued by the \*[Commandant] from day to day. The relevant Police Rules shall be complied with.

---

\* Substituted vide CPO, Pesh: Memo: No. 789/PA/Oprs: dated 06.02.2012.



**ROLL CALL.****Rule No. 102.**

The roll call shall be held daily at the time to be fixed by the \*[Commandant]. The Reserve Inspector shall be present at all roll calls at which men shall be detailed for duty and the day's program announced. All orders and instructors shall be similarly announced and a record of this shall be maintained.

**STANDING ORDER.****Rule No. 103.**

A file containing all standing orders shall be maintained in the office of the \*[Commandant], Chief Law Instructor, Reserve Inspector and Chief Drill Instructor and by such other officials as required to do so under these rules. They shall remain in force until cancelled.

**AUTHORIZED SOCIAL WORK, \*[KHPAL KAR].****Rule No. 104.**

All trainees shall be liable to perform authorized social work (Khpal Kar) which is necessary to keep the premises of the institution clean, neat and tidy. The social work should be conducted in such a manner which should install the spirit of self-help and dignity of labor. The trainees shall be made to realize that in the course of their service, there will be circumstances which will require them to do similar social works. Such social work shall in no case be permitted to interfere with the attendance of any trainee from \*[College] and Parade. Police Rule 19-7 shall strictly be observed in this respect.

**KEEPING OF PET AND ANIMALS.****Rule No. 105.**

No trainee shall be permitted to keep any pet or animal. Members of the staff who keep domestic pets and other animals shall be responsible for their look- after. They shall also ensure that the animals are always under control and are not permitted to cause any damage to the premises of the institution. The owners whose animals or birds become a source of nuisance shall be impounded/caged and the damage done will be recoverable from them.

---

\* Substituted vide CPO, Pesh: Memo: No. 789/PA/Oprs: dated 06.02.2012.

## MEASURES TO BE TAKEN IN CASE OF AN EPIDEMIC.

### Rule No. 106.

Whenever a case of contagious disease is reported, the medical officer and the District Health Officer shall be informed immediately. Steps would be taken to isolate the case. If necessary, complete barracks or residential quarters shall be placed in quarantines and out of bound for the members of the staff and trainees. Immediate steps will be taken to initiate preventive measures amongst personnel living in the vicinity. In the case of serious outbreak of an epidemic in which there is a possibility of the epidemic spreading and affecting the entire Institution, the matter will be reported to the \*[Provincial Police Officer] and orders to close the Institution for the period of the epidemic be solicited.

## SANITARY AND CLEANLINESS.

### Rule No. 107.

It shall be incumbent upon all occupants of family quarters, barracks and other residential places to keep their premises neat and clean and to report the occurrence of any contagious disease immediately. The premises of the Institution may be divided and responsibility for their maintenance and cleanliness placed upon various companies.

## GUARD DUTY.

### Rule No. 108.

Sanctioned guards shall be mounted from the standing order shall be issued in respect of each guard.

## EMERGENCY DUTIES.

### Rule No. 109.

\*[Deleted. Occasionally it has to be done by the PPO.]

---

\* Substituted vide CPO, Pesh: Memo: No. 789/PA/Oprs: dated 06.02.2012.



## METHOD OF INSTRUCTION.

### Rule No. 110.

The instructions must always be clear and concise. The important points should be illustrated and demonstrated wherever possible. Free use shall be made of all training aids including black boards, Audio Visual Aids and models. Since the police man is required to perform his duties both individually and collectively, the training should be imparted in a manner to create initiative, resourcefulness, self-confidence and leadership in him. For this purpose, his ability to discipline himself, to receive and comply with orders and instructions, his sense of responsibility and commandship will require proper coaching. There should be frequent questioning to ascertain the assimilation of the trainees. Students should be encouraged to enter into discussions. The instructions may take a form of personal or collective tasks. Last ten minutes of each period may be utilized for questions/answers by the trainees. The instructors should acquaint themselves with instructional techniques.

## USE OF AUDIO VISUAL AND OTHER AIDS.

### Rule No. 111.

The maximum use shall be made of all training aids. Instructors should be encouraged to devise their own training aids in addition to the conventional ones. For this purpose a separate section should be formed to prepare and maintain the training aids. Appropriate attention should be given to the establishment of archives of training and informative films and recording of good lectures and discussions. Instructors should be encouraged to suggest material for the preparation of film slides, film strips, charts and models.

## TRAINING IN DRILL.

### Rule No. 112.

The purpose of physical training is to keep the trainees fit and healthy to withstand the strains of Police man's daily life.

The training shall be carried out on the lines indicated in the prescribed manual. The occasional \*[...] test in the form of obstacles course would be necessary to test the individual physical fitness. The training however should not become irksome. The art of Judo and un-armed combat shall be included in the training program.

---

\* Substituted vide CPO, Pesh: Memo: No. 789/PA/Oprs: dated 06.02.2012.

## GUEST SPEAKER

### Rule No. 113.

The \*[Commandant] should periodically invite guest speaker to address both the staff and students on general subjects. Such guests shall be entertained from private funds of the \*[College]. Important speeches of guest speakers will be preserved in the record of library.

## VISIT TO PLACES OUTSIDE THE INSTITUTION.

### Rule No. 114.

The \*[Commandant] may if he feels that the students would benefit, take class of students to places outside the institution on study tours.

## FIRST AID.

### Rule No. 115.

First aid should be taught to all trainees who shall be required to attain the standard specified by Red Cross Society. Instructions in first aid shall be given by the Medical officer In-charge \*[.....] Hospital.

## SWIMMING.

### Rule No. 116.

Trainees shall be taught how to swim\*[ , ride and drive].

## MUSKETRY.

### Rule No. 117.

\*[Deleted, not in practice.]

## SANCTIONED STAFF OF P.T.C

### Rule No. 118.

The strength will be sanctioned, from time to time, by the \*[PPO] Peshawar.

Under no circumstances, the staff sanctioned above to be left deficient. The \*[Commandant] shall immediately bring the deficiency if any to the notice of the

\* Substituted vide CPO, Pesh: Memo: No. 789/PA/Oprs: dated 06.02.2012.



Provincial Police Officer or the officer authorized by him on his behalf. This sanctioned staff suffices the purpose of training to the \*[...] maximum number of trainees efficiently.

\*[.....]

In case the departmental demand increases, the \*[Commandant] shall bring into the notice of the \*[Provincial Police Officer], or other authorized officer to post extra staff, according to the needs on temporary basis till the emergency demands are met.

If some new courses are intended to be introduced, a committee comprising a Dy. Inspector General of Police, \*[Commandant] and one \*[District Police Officer] be nominated by the \*[Provincial Police Officer] to consider the matter regarding the increase and selection of staff required for such training. The committee will submit its recommendation to the \*[Provincial Police Officer] for taking up the case with the Provincial Government for sanction. Additional Inspector General of Police, Headquarters, Peshawar shall personally pursue the case and progress reported to the \*[Provincial Police Officer].

Presently Instructional staff for Law subjects is from ranks. In order to impart good training and make the students fully conversant with the subjects taught to them it is imperative that instead of ranks specially qualified persons for such subjects are employed by offering them suitable grades as is allowed in the cases of lecturers of the college. This will certainly enhance the professional capability of the Police Officers. In this context efforts should be made to get such posts sanctioned from the Provincial Government.

## SELECTION OF INSTRUCTORS.

### Rule No. 119.

- a. The \*[Commandant] will have the sole authority to select suitable officers of the prescribed ranks, from the whole of the Province. \*[The Commandant will call men from the districts / units along with their service record / character rolls, interview the men and see their service record / books. The names of suitable officers will be recommended to the PPO for proper posting order to the training institutes.]
- b. It would be obligatory upon \*[CCPO and] all Dy. Inspector General of the Ranges \*[Commandant FRP and the District Police Officers] to relieve the selectees within a week time without considering any representation against such posting orders directing him to report at Police Training \*[College]. The evasion in any manner from the compliance of posting orders will be a serious misconduct on the part of the officer.
- c. The authorized officer will be competent to make posting orders of any selectee Police officer serving in any part of the Province. Such posting orders should be deemed to have been issued by the Provincial Police Officer. The vacancies so

\* Substituted vide CPO, Pesh: Memo: No. 789/PA/Oprs: dated 06.02.2012.

occurred in Ranges/Districts shall be filled in by the Central Police Office in case of \*[officers from the rank of ASI to Inspector] and Range Offices in case of \*[officers below the rank of ASI].

d. \*[Deputation period of the staff at training institutions will be three years. Extendable upto five years.

Posting period of any instructor even on deputation/loan would not be less than three years.

Every staff member will be subjected to fire maximum one hundred rounds in six months period as practice firing. The ammunition spent will be provided from the service stock placed at the disposal of the Commandant PTC Hangu.]

e. \*[Deleted]

f. On administration side seasoned and experienced officer with good academic qualifications are required to be posted from the department.

### **SANCTIONED STRENGTH OF LAW STAFF.**

#### **Rule No. 120.**

a. The Law Instructors shall specialize in one subject and each Instructor should attend at least two periods a day. In cases where the extra load comes in, the \*[Commandant] should inform the \*[Provincial Police Officer]/other authorized officer, for the temporary increase of the Instructional staff from the ranges and Districts of the Province so that the training is imparted in its right perspective. Ordinarily the total students in one class should not exceed thirty in number.

b. Lines Staff: The lines staff hardly suffices the administration duties of the Police Training \*[College] and there is left no Constable to be posted as orderly to the authorized officer of the Police Training \*[College]. To meet this necessity it should *be binding upon the districts to provide and allow the officer to bring with him his orderly to Police Training \*[College] at the time of his posting. The pay etc. shall be paid by the district concerned and will be deemed to have been serving in the same district for the purpose of allowances admissible in that district.*

---

\* Substituted vide CPO, Pesh: Memo: No. 789/PA/Oprs: dated 06.02.2012.



## QUALIFICATIONS FOR POSTING TO POLICE TRAINING COLLEGE.

### Rule No. 121.

#### I. LAW STAFF

- a. Law staff instructor who teaches law should preferably be a law graduate.
- b. For training and teaching of Police Practical Work, there will be a graduate instructor with good service record. Relaxation in academic qualification may, however, be considered in case of professionally competent Police Officer.

#### II. DRILL STAFF.

The qualified officer in Drill Instructor Course with good reputation and having at least five years' service in the department may be considered for posting as Drill Instructor at Police Training \*[College]. Preference will be given to the educated personnel.

#### III. ADMINISTRATIVE STAFF.

Officers with unblemished record of service shall be posted to Police Training \*[College]. In case of Reserve Inspector, an officer likely to be promoted to the next rank within two or three years shall be considered for posting so that his authority on the basis of seniority remains effective.

- IV. \*[The Commandant shall, except those officers reported upon in form 13-17 of Police Rules, report in form No. 19-22(3) Police Rules on the working of Drill Instructors serving on deputation or loan, and in form No. 121 (IV) of the PTC Hangu, Manual, on the working of other staff serving on deputation or loan. These reports shall reach, on or before 15<sup>th</sup> February each year, to the parent District/Unit of the staff members concerned.]

### PAY OF TRAINEES.

#### Rule No. 122.

This will be the sole responsibility of the \*[CCPO, Peshawar, District Police Officers and other heads selecting trainee,] to draw the pay of the trainees and arrange its disbursement upon them through their Lines Officers or other specially detailed officers. Only in case of the trainee of Chitral District and Northern Areas, their pay shall be sent to the \*[Commandant], Police Training \*[College] through Bank Draft

\* Substituted vide CPO, Pesh: Memo: No. 789/PA/Oprs: dated 06.02.2012.

along with Acquittance Rolls etc, for disbursement.

The disbursing officers of various districts shall first report to the Reserve Inspector of Police Training \*[College] who will detail with them the \*[P.T.C] official responsible for making deduction of mess charges etc. From the trainees all disbursement shall be made in the presence of Police Training \*[College] officials. In case of bank drafts received from Chitral and other districts mentioned above, the Pay Officer and the Lines officer shall arrange its encashment and disbursement required under the rules. In case the un disbursed amount of the trainees who have returned to their districts or deserted shall immediately be deposited with the pay officer who will be responsible to dispatch the un disbursed amount to their respective districts within a week time. The district \*[selecting authority] must ensure that the pay of the trainees is sent to Police Training \*[College] on the 4<sup>th</sup> of every month positively so that trainees may not face financial hardships and be able to clear the outstanding amount of mess charges etc.

### AMINITIES FOR STAFF AND TRAINEES.

#### Rule No. 123.

It should be the constant endeavor of the \*[Commandant] to provide amenities and other social welfare facilities to the members of the staff, their families and all trainees. Such amenities as libraries, canteen, regimental shop, recreation rooms, officer's clubs, child welfare/ maternity centers etc. shall invariably be provided.

---

\* Substituted vide CPO, Pesh: Memo: No. 789/PA/Oprs: dated 06.02.2012.



## END OF TERM FUNCTION.

### Rule No. 124.

At the end of each term a dignitary will be invited as a guest of honor to review the passing out parade and give away the prizes to the position holders on the eve of the passing out parade.

## VISITORS BOOK.

### Rule No. 125.

A visitor's book shall be maintained in the office of the \*[Commandant] in which a guest of honor invited on some particular occasions to Police Training \*[College] or other V.V.I.P/V.I.P will be requested to enter his remarks.

## PRIZE ENTITLEMENT.

### Rule No. 126.

All those trainees who stand first in \*[Sub Inspectors Legal Course], Upper \*[College] Course, Intermediate \*[College] Course, Lower \*[College] Course and Recruit \*[College] Course will be awarded a commendation certificate by the \*[Commandant] with a cash reward of Rs.\*[1000]/- each. Those who stand first in musketry will be awarded a commendation certificate of Rs.\*[500]/-. \*[Recruit who declared as Best in Parade will be awarded a commendation certificate with a minimum cash reward of Rs.500/-.] The best sports man will also be awarded a commendation certificate with a cash reward of Rs.\*[500]/- by the \*[Commandant]. Each commendation certificate awarded to the winner of any sports event shall carry three marks. These marks will be added to their grand total marks obtained in law and drill subjects benefit them in their merit position.

## LAW SUBJECTS.

### Rule No. 127.

\*[Deleted, as courses and the allied matters have been mentioned in Rule.No.10 of chapter No.2 of the Manual. No need to mention all subjects specifically as they are updated and amended from time to time.]

---

\* Substituted vide CPO, Pesh: Memo: No. 789/PA/Oprs dated 06.02.2012

## DRILL SUBJECTS FOR RECRUITS.

### Rule No. 128.

\*[Deleted, as courses and the allied matters have been mentioned in Rule.No.10 of chapter No.2, of the Manual. No need to mention all subjects specifically as they are updated and amended from time to time.]

## GENERAL.

### Rule No. 129.

\*[Deleted, as the purpose of this rule had already been mentioned in the new rule 14C.]

## RECRUITS TRAINING CENTRE.

### Rule No. 130.

The \*[Commandant] Police Training \*[College], Hangu will pay occasional visits to the Recruit Training Centers and other Training Institutions in order to see that the training program is carried out efficiently. He will also submit his suggestions/recommendations/ in respect of training in these training centers about any addition/ deletion in the courses being taught there to the \*[Provincial Police Officer] or authorized, officer for approval.

## MISCONDUCT.

### Rule No. 131.

\*[In addition to the punishments authorized to the senior officers under different rules and regulations, the staff/ trainees may be awarded the following punishments for their misconduct.

- i. Defaulter drill
- ii. Fatigue duties

A trainee who is returned unqualified to his district may be considered by the Region Dy. Inspector General/ District Police Officer in the next ten's, keeping in view the gravity of his misconduct due to which he was reverted to the district as unqualified, subject to the concurrence of the Commandant.

\* Substituted vide CPO, Pesh: Memo: No. 789/PA/Oprs: dated 06.02.2012.



In case of disagreement the final decision will lie with the Provincial Police Officer.]

### STANDING ORDERS.

#### Rule No. 132.

\*[All orders will be entered in the daily order book and will be read out to the trainees in evening roll call.]

### CHEATING IN EXAMINATION.

#### Rule No. 133.

\*[i. A trainee/ recruit found guilty of the cheating in any examination shall be subjected to one of the following punishments keeping in view the gravity of the misconduct.

1. Relegation/Reversion

2. Fine

3. Debarring him from re-admission for a period up to two years.

ii. The provisions of this rule shall equally apply to annual A-1 & B-1 examinations.]

### SECURITY DEPOSITS.

#### Rule No. 134.

\*[Deleted, as it has never been done.]

### TEST BOOKS.

#### Rule No. 135.

\*[Deleted, as it is not practical.]

## SHOP KEEPERS.

### Rule No. 136.

The \*[Commandant] allow any shop keeper, hawker or contractor to run a shop or sell eatables etc. within the premises of \*[College]. They will pay monthly rent fixed by the \*[Commandant] regularly which will be credited to the \*[College] Fund.

## INSTRUCTION.

### Rule No. 137.

The \*[Commandant] is authorized to issue instructions governing the internal working and administration of the \*[College].

The \*[Provincial Police Officer] is competent to frame, amend, alter, annul, and issue any order, instructions and rules in addition to any of the rules.

## \*[SUPERVISORY OFFICER]

### Rule No. 138

From Dy. Commandant down to the rank of Inspector would detail an officer to supervise the working of the institution dawn to dusk. Report in this regard would be directly submitted to the Commandant in Form No. 138.]

## \*[DUTY OFFICER]

### Rule No. 139

There will be two Duty Officers at a time from the staff i.e Inner Duty Officer and Outer Duty Officer for duty of 6 hours at daytime and 6 hours at night.

The Inner Duty Officer shall:

- a. Responsible for the security of his area of responsibility.
- b. Check the trainees and staff on social work.
- c. Check the rates of utility items at regimental and canteen and check quality and service standard.
- d. Check all sentries stationed in his jurisdiction, their uniforms and punctuality on duty.
- e. Check patrolling duty.
- f. Check Magazine Guard and, Quarter Guard, Kot and arms distributed for duties to the officers.
- g. Submit a detail report, in prescribed form No. 139(g), covering all the affairs such notice during his duty time, and suggestions for improvement of the discipline, security, cleanliness etc.

---

\* Substituted vide CPO, Pesh: Memo: No. 789/PA/Oprs: dated 06.02.2012.



**Outer Duty Officer**

The outer Duty Officer, will be responsible to patrol the external area of PTC Hangu situated outside the boundary wall.

He shall:

- i. Check the trainees and staff on social work.
- ii. Check all sentries stationed in his jurisdiction, their uniforms and punctuality on duty.
- iii. Check the patrolling officials, their alertness and turnout.
- iv. Check the Mazhar Parade Ground, firing ranges, hilltop etc.
- v. Submit a detail report, in prescribed form No. 139 (v), covering all the affairs appear to him in his duty time, and suggestions for betterment of the discipline, security, cleanliness etc.

**\*[ORDERLY ROOM****Rule No. 140**

(a) Any staff member/trainee may appear before the Commandant in the orderly room to request his help in respect of any problem being faced by him.

For this purpose he would submit an application in the form No. 140 (a).

(b) Any senior officer may recommend Commendation Certificate and reward for staff members/trainees by highlighting the commendable performance in form No. 140

(b).]



فارم زیر قاعدہ ۲۶ - (vii) پی ٹی سی ہنگو مینول

درخواست برائے چھٹی \_\_\_\_\_ کمپنی \_\_\_\_\_  
 نام، نمبر، عہدہ \_\_\_\_\_ سٹاف / کورس \_\_\_\_\_ رہائشی \_\_\_\_\_ آمدہ ضلع \_\_\_\_\_  
 سینٹر، انٹر، جوئیر  
 رخصت استدعا، آیام \_\_\_\_\_ از \_\_\_\_\_ تا \_\_\_\_\_  
 وجہ: \_\_\_\_\_

دستخط درخواست دہندہ \_\_\_\_\_ تاریخ \_\_\_\_\_

سابقہ رخصت	غیر حاضر	ریٹ	میڈیکل ایو	آخری رخصت / SL/WE
_____ ٹوٹل	_____ ٹوٹل	_____ ٹوٹل	_____ ٹوٹل	_____ از _____ تا _____ ٹوٹل

رپورٹ ریکارڈ آفس \_\_\_\_\_ افسر مجاز \_\_\_\_\_

کمانڈنٹ صاحب \_\_\_\_\_





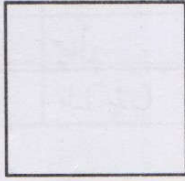

پلی ٹی سی، سکول

ٹرم آغاز \_\_\_\_\_

ٹرم اختتامی \_\_\_\_\_



فارم زیر قاعدہ ۳۰ (ب) (i)

ریکارڈ رجسٹر برائے Pre-Service کالج کورس

کورس \_\_\_\_\_

رجسٹریشن نمبر \_\_\_\_\_ نام \_\_\_\_\_ نمبر \_\_\_\_\_ عہدہ \_\_\_\_\_ تعلیم \_\_\_\_\_ آمدہ ضلع \_\_\_\_\_ تاریخ پیدائش \_\_\_\_\_ تاریخ بھرتی \_\_\_\_\_ کورس کے آغاز پر کل عمر \_\_\_\_\_

ولدیت \_\_\_\_\_ قوم \_\_\_\_\_ مذہب \_\_\_\_\_ سکونت \_\_\_\_\_ حقانہ \_\_\_\_\_ تحصیل \_\_\_\_\_ بلڈ گروپ \_\_\_\_\_ شناختی کارڈ نمبر \_\_\_\_\_

جسمانی بیماری \_\_\_\_\_ جسمانی معذوری \_\_\_\_\_ ٹیلی فون نمبر \_\_\_\_\_ متعلقہ حاکم کی چھٹی نمبر \_\_\_\_\_ حاکم جس کے پاس نتیجہ کورس جائے گا \_\_\_\_\_

ترتیبی پروگرام میں عدم شمولیت اور دی گئی سزاؤں، جزاؤں کی تفصیل

نمبر شمارہ	رضت		غیر حاضر		آڈٹ ڈوران ڈوریٹ		شہادت ایگرا کارڈ		درجہ نمونہ پوروش	سزائیں	تاریخ معذرتکارا خارج	نام _____
	تا	از	تا	از	تا	از	تا	از				
1												
2												
3												
4												
5												
6												
تفصیل	قد	مہارت	وزن	تفصیل جسمانی معیار میں اگر کوئی کی ہو تو	تاریخ مکمل نہ کرنے کی صورت میں وجوہات							
آہٹ												
انتظامیہ												





فارم زیر قاعدہ ۸۵ (i) پی ٹی سی ہنگو مینول

ٹائٹل رول برائے Pre-Service کورسز

نام کورس \_\_\_\_\_ ٹرم آغاز \_\_\_\_\_

کوائف	عنوان	نمبر شمار
	نام	۱
	بیلٹ نمبر	۲
	رتبہ (عہدہ)	۳
	ولدیت	۴
	گاؤں محلہ	۵
	سکونتی تھانہ	۶
	تحصیل	۷
	سکونتی ضلع	۸
	بھرتی ضلع / ایونٹ	۹
	کمپیوٹرائزڈ شناختی کارڈ	۱۰
	بلڈ گروپ	۱۱
	گھری ذاتی فون / موبائل نمبر	۱۲
	تعلیم	۱۳
	تاریخ بھرتی	۱۴
	تاریخ پدائش	۱۵
سال ..... مہینہ ..... دن .....	قد	۱۶
	چھاتی	۱۷
	عملہ (کیڈر)	۱۸

دستخط سربراہ ضلع / ایونٹ



فارم زیر قاعدہ ۸۵ (ii) پی ٹی سی ہنگو مینول  
 ٹائٹل رول برائے In-Service کالج کورس

نام کورس \_\_\_\_\_ ٹرم آغاز \_\_\_\_\_

نمبر شمار	عنوان	کوائف
۱	نام	
۲	پیلٹ نمبر	
۳	رتبہ (عہدہ)	
۴	ولدیت	
۵	گاؤں / محلہ	
۶	سکونتی تھانہ	
۷	تحصیل	
۸	رہائشی ضلع	
۹	بھرتی ضلع / یونٹ	
۱۰	کمپیوٹرائزڈ شناختی کارڈ نمبر	
۱۱	بلڈ گروپ	
۱۲	گھریا ذاتی فون / موبائل نمبر	
۱۳	تعلیم	
۱۴	تاریخ بھرتی	
۱۵	تاریخ پیدائش	سال _____ مہینہ _____ دن _____
۱۶	کورسز جو پاس کئے ہیں	

دستخط سربراہ ضلع / یونٹ







قارم زیر قاعدہ ۱۴۱ (iv) پولیس ٹریننگ کالج ہنگو مینول  
سالانہ کارگزارری رپورٹ ملازمان تعینات شدہ پولیس ٹریننگ کالج ہنگو، RTW کوہاٹ، RTW مانسہرہ یادگیر ٹریننگ سنٹر

نمبر شمار	تفصیل	کیفیت
۱	نام پولیس آفسر	
۲	بلیٹ اریج نمبر	
۳	رتبہ	
۴	آبائی ضلع ایونٹ	
۵	ٹریننگ سنٹر میں آمد کی تاریخ	
۶	قسم تعیناتی آن ڈیپویشن آن لون	
۷	رپورٹ کا عرصہ	از ----- تا -----
۸	کورس پاس کردہ کی تاریخ	
	i- لوئر	
	ii- انٹرمیڈیٹ	
	iii- ڈرل انسٹرکٹر	
	iv- ATS	
	v- ایلپیٹ فورس	
	vi- بھاری ہتھیار	
	vii- دیگر مہارت	
۹	قسم ہندی رپورٹ یعنی ا، ب، ج	
۱۰	رائے ڈپٹی کمانڈنٹ / CLI / DSP ایڈمن	
۱۱	ناثرات کمانڈنٹ	

کمانڈنٹ  
پولیس ٹریننگ کالج ہنگو





فارم زیر قاعدہ ۱۳۸ پی ٹی سی ہنگو مینٹول  
Daily Supervisory Report

By.....Date.....

پریٹ: (ٹرن آؤٹ، معیار پریٹ، غیر حاضر اساتذہ، ٹرینی اینڈش کوآرڈیگٹرز)

میس دوران ناشتہ: (صفائی وردی ٹرینیز / کپڑے کلاس فور، کاروائی؟)

سکول: (کن کن کلاسوں میں انسٹرکٹرز بمطابق ٹائم ٹیبل تھے)

میس دوران نظیر اند / عشائیہ

سہ پہر ٹیبل کار: (معیار کام، معیار Supervision / کھیل / انچارج موجود / غیر موجود)

کینٹین

(صفائی، تنظیم، انتظام)

---



---



---



---

تظار کی پابندی

---



---



---



---

شام کی گنتی:

(غیر حاضر اساتذہ، مہتمم، دیر سے آنے والے، خطاب کا خلاصہ)

---



---



---



---

DO ڈیوٹی:

(معیار ڈیوٹی پر تبصرہ، کمانڈنٹ کے جاری کردہ احکامات کی روشنی میں)

---



---



---



---

ڈپلن ڈیوٹی والوں کی موجودگی و کار

---



---



---



---



یکورٹی:

-----  
 -----  
 -----  
 -----

(نافذ کردہ)

سزا

-----  
 -----  
 -----  
 -----

(تجویز کردہ)

جزاء

-----  
 -----  
 -----  
 -----

(کالج کے ماحول کی بہتری کے لئے)

مزید کوئی بات یا تجویز:

-----  
 -----  
 -----  
 -----

دوران پریڈا ایجوکیشن (دو دنوں ٹائم) بمعدہ رانیور کی موجودگی

-----  
 -----  
 -----

کمانڈر مشن

دستخط

-----

-----



فارم زیر قاعدہ ۱۳۹ (g) پی ٹی سی ہنگو مینول  
رپورٹ DO اندرون ایریا پی سی سی

مورخہ

عہدہ

نام

۱۔ رپورٹ ازان خلیل کار (حاضری اساتذہ، ٹیچرز، پرائمرس کام وغیرہ)۔ رپورٹ ازان کوت مسجد

۲۔ رپورٹ ازان سنتریان (وردی، ہوشیاری، پابندی وقت، ذمہ داری وغیرہ) کس پوسٹ کے قریب کاغذ وغیرہ پانے پر کاروائی کی۔ کیا تمام پودوں کو پانی دی گئی ہے۔ سیکٹر میں تمام ٹین گند سے خالی تھے۔ سیکورٹی ڈیوٹی پر مامور سٹاف کا ٹرن آؤٹ (وردی، بوٹ، شیوا اور بیگز کٹ)

۳۔ گنتی ختم ہونے پر ٹیچرز ریگرائی کینی حوالدار ڈسپلن میں کینی / میس لے جا رہا تھا۔  
رپورٹ ازان گشت (نظم، دلچسپی، ذمہ داری وغیرہ) سنتری پوسٹوں کی حالت۔ دوران کھانا ٹیچرز قطار میں موجود۔

۴۔ میس میں میزیں اور فرش صاف تھے خدمتی CC اپنی ڈیوٹی درست طور پر سرانجام دے رہے تھے۔ کپڑے میس ہالوں کی صفائی



5- ہاسٹل، کینیوں اور چھوٹیوں کی صفائی کے متعلق رپورٹ اپرانے لیٹرینوں پوائنٹ نمبر 1 پانی نیٹکی کے پاس گند

6- رپورٹ ازاں کینٹین معیار یا صفائی، رہنمائی شاپ زرخ امیس کھانے کی معیار، روٹی کا وزن، ڈیوٹی پر موجود ہلکاران

7- بجلی کا نظام لائیت (بلب وغیرہ) کے متعلق رپورٹ، مسجد کے غسل خانوں کی صفائی۔ حدود پی ٹی سی کے تالوں کی صفائی  
ڈسپن ڈیوٹی والے انسٹرکٹرز ڈیوٹی پر موجود تھے۔ کارگزاری کے متعلق رپورٹ

8- تجویز (اگر کوئی ہو)۔

9- خصوصی رپورٹ اگر کوئی ہو۔ کن کن درختوں کی شاخ تراشی درکار ہے۔

10- رات کو روزنا چھ میں ڈرائیور کی موجودگی مسجد ہاسٹل نمبر 2 میں بوقت 0200 بجے پانی گرم کرنے کا کام شروع ہوا ہے اینڈش کو آرڈر کارڈ  
میں ٹرینیز کے پاس بستر یا چادر موجود تھا دوران پریڈا ایسولنس بمسڈ ڈرائیور موجود تھی۔

D.O

ڈپٹی کمانڈنٹ



فارم زیر قاعدہ ۱۳۹ (v) پی ٹی سی ہنگو مینول  
رپورٹ DO بیرونی ایریا پی ٹی سی

DATE \_\_\_\_\_

عہدہ \_\_\_\_\_

نام \_\_\_\_\_

۱۔ رپورٹ ازاں چیل کار (حاضری، اساتذہ، ٹرینیز، پراگرس کام وغیرہ)۔ سیکٹر میں تمام ٹین گند سے خالے تھے کیا تمام پودوں کو پانی دیا گیا ہے۔

۲۔ رپورٹ ازاں سنتریان (وردی، ہوشیاری، پابندی وقت، ذمہ داری وغیرہ)۔

۳۔ رپورٹ ازاں گشت (نظم، دلچسپی، ذمہ داری وغیرہ)

۴۔ مظہر پریڈر اوٹڈ، لانگ بٹ، پہاڑی ٹاپ وغیرہ کے متعلق رپورٹ اچوکیدار کی موجودگی؟



۵۔ کیا ضلع سے ٹریفک کا سپاہی بغرض ڈیوٹی آیا۔ اگر نہیں تو کیا کیا گیا

۶۔ بجلی اور لائمیٹ کے نظام کے متعلق رپورٹ

۷۔ کن پوائنٹوں کے قریب کاغذ وغیرہ پائے گئے اور کارروائی؟

۸۔ تجویز/خصوصی رپورٹ اگر کوئی ہو۔

دستخط D ----- ڈپٹی کمانڈنٹ ----- کمانڈنٹ -----







فازم زیر قاعدہ ۱۴۰ (ب) پی ٹی سی ہنگو میٹول  
تقدیر سفارش ملازمان پولیس ٹریننگ کالج ہنگو

نمبر شمار	نام نمبر عہدہ ملازمان	کارکردگی	افسران سفارش کنندہ	حکم